

PERFORMANCE UNDER PRESSURE

*Principles Of
Pressure Regulation*

*with Performance Curves
For Wilkins
Pressure Regulators*

WILKINS



the need to **CONSERVE NATRAL RESOURCES**

Because of growth, we are faced, more and more, with the challenge to protect our environment. Conserving our energy and water supply is one of the most important aspects of this global challenge. Since we cannot increase our supply, we must reduce our consumption. After years of carelessness, we have finally recognized the need for a more responsible pattern of water use. Fortunately there is a simple solution to reducing consumption without changing our lifestyles.

solution- **THE WILKINS REGULATOR**

The simple solution is the use of water Pressure Reducing Valves, or Regulators. These devices are an automatic control which is installed at the water meter in homes to reduce the city main pressure to a lower, more functional pressure. When the water pressure is reduced, less water is used. The average savings per year per home would be between 30,000 and 40,000 gallons of water. If these saving were applied to a million homes, consider the impact this would have on our consumption goals. Pressure Reducing Valves are equally effective for use in commercial buildings and irrigation systems.

DUAL BENEFITS

Not only is installing a water Pressure Reducing Valve good for the environment, it saves money as well. Excessive water pressure can be harmful to a home plumbing system, causing damage to pipes, faucets, and appliances. Regulators increase the life span of dishwashers and water heaters and reduce the noise of banging pipes caused by the “water hammer” effect.

Water Conservation

Reducing the pressure from 100 psi to 50 psi would result in roughly one-third less water consumption in the average household. This means not only reduced consumption, but a lower water bill, as well. On top of this, the water is “saved” again because there is one-third less wastewater entering the sewer system. Many sewer bill taxes or surcharges are based on the amount of water that you use, with the assumption that this is the amount of water that will eventually enter the wastewater system. In this way, savings on the water bill will also result in savings on the sewer bill. This benefits both individual households, and the community as a whole, which has less sewage water to treat.



Energy Conservation

It is estimated that nearly 30% of the water used in households is heated, and in order to heat this water, it takes energy. Logically, if a Pressure Reducing Valve can reduce water use by one-third, it will also cut down on the amount of water that has to be heated. Thus, we can easily see that water conservation is directly linked to lower rates of energy consumption.

Plumbing Codes - Safety

Most National Plumbing Codes require the installation of Pressure Reducing Valves when local static water pressure is in excess of 80 PSI. The addition of a Wilkins Pressure Reducing Valve will fulfill this code requirement while giving the added benefit of reducing wear in other plumbing system components that would occur as the result of excessive pressure. Long-term exposure to high pressure can result in system component breakage, causing flooding and property damage. Insurance companies are less inclined to insure property that has experienced water damage, due to the possibility of mold growth. Check with your insurance carrier for details.

Irrigation Systems

Irrigation system components usually require a pressure below 70 PSI to function properly. Premature solenoid control valve and/or sprinkler head failure, and water hammer, nozzle fogging and misting are all tell-tale signs of excessive pressure in an irrigation system. Wilkins Pressure Reducing Valves will eliminate the frustration and expense of replacing these components on a frequent basis, as well as preventing inadequately watered landscape and water waste due to over-watering and evaporation.

WILKINS REGULATOR APPROVALS

MODEL	ASSE	IAPMO/CITY OF LA	CSA
500	1/2" - 2 1/2"	1/2" - 2 1/2"	1/2" - 2"
500YSBR	1/2" - 2 1/2"	1/2" - 2 1/2"	1/2" - 2"
600	1/2" - 2"	1/2" - 2"	1/2" - 2"
70	1/2" - 2"	1/2" - 2"	1/2" - 2"
BR4	1/2" - 2"	1/2" - 2"	1/2" - 2"
BR4EC	1/2" - 1"	1/2" - 1"	1/2" - 1"
BR5	3/4" - 1"	3/4" - 1"	

how water PRESSURE REGULATORS OPERATE

Pressure Reduction

A Pressure Regulator is a Pressure Reducing Valve designed to reduce high inlet pressure to a lower outlet pressure. The WILKINS direct-acting Pressure Reducing Valve is a normally open valve that is biased to the open position by a pre-loaded spring (1). The valve will remain in the open position until downstream (reduced) pressure forces the plunger (2) on to the seat (3), thereby closing the valve. The act of closing the valve is accomplished by the reduced pressure water pushing on the wetted side of the diaphragm (4). The reduced pressure water exerts a force on the diaphragm (4) in a

direction opposite of the spring (1), thereby closing the valve. Therefore, the amount of reduced pressure is directly proportional to the pre-loaded spring (1). When the valve is pressurized, the reduced pressure water pushing on the wetted side of the diaphragm (4) holds the valve in the closed position until a demand is placed on the plumbing system downstream of the regulator. As soon as demand occurs, the amount of reduced pressure water pushing on the wetted side of the diaphragm (4) decreases, allowing the spring (1) to bias the valve open in order to satisfy the demand placed on the plumbing system. The valve will continue to modulate in the open position until the demand placed on the plumbing system ceases. At that point, the valve will again close. Further, since the operating intelligence for Pressure Reducing Valves is independent of inlet pressure, Pressure Reducing Valves are capable of holding the static

downstream pressure within very narrow limits, regardless of inlet pressure fluctuations.

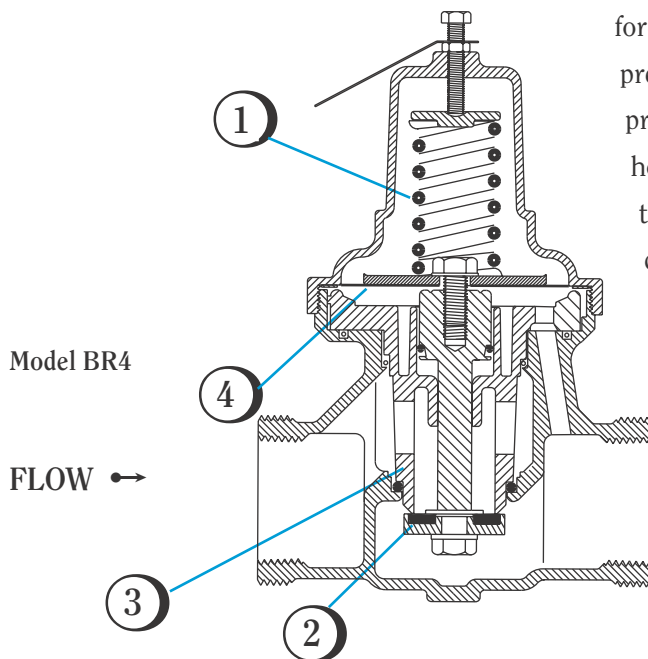

Integral By-pass

The Integral By-pass is designed to keep the plumbing system pressure, downstream of the Pressure Reducing Valve, below the Temperature & Pressure Relief Valve (installed on the hot water heater) opening point when the incoming water pressure is less than 150 PSI. This operation is accomplished through the use of an o-ring in a conic o-ring gland (5). Under normal working conditions, where water pressure coming into the regulator is greater than the water pressure downstream of the

regulator, the o-ring is pushed into the narrow section of the gland by incoming water pressure and seals tight. In the event that the pressure on the downstream side of the regulator becomes equal to the incoming pressure, the o-ring will slide to the wide section of the gland and sealing can no longer be facilitated. When this action occurs, equilibrium will be maintained and the downstream pressure will never become greater than the upstream pressure. This will prevent the downstream pressure from rising to the Temperature & Pressure Relief Valve opening point, (usually 150 psi). It must be noted that the By-pass feature will not work in applications that have a Backflow Preventer in the incoming water line or if the incoming pressure is greater than the Temperature & Pressure Relief Valve opening point. Should these conditions be present in the system, a Thermal Expansion Tank (Wilkins WXTP series) would be the proper means of controlling the elevated pressure downstream of the regulator.

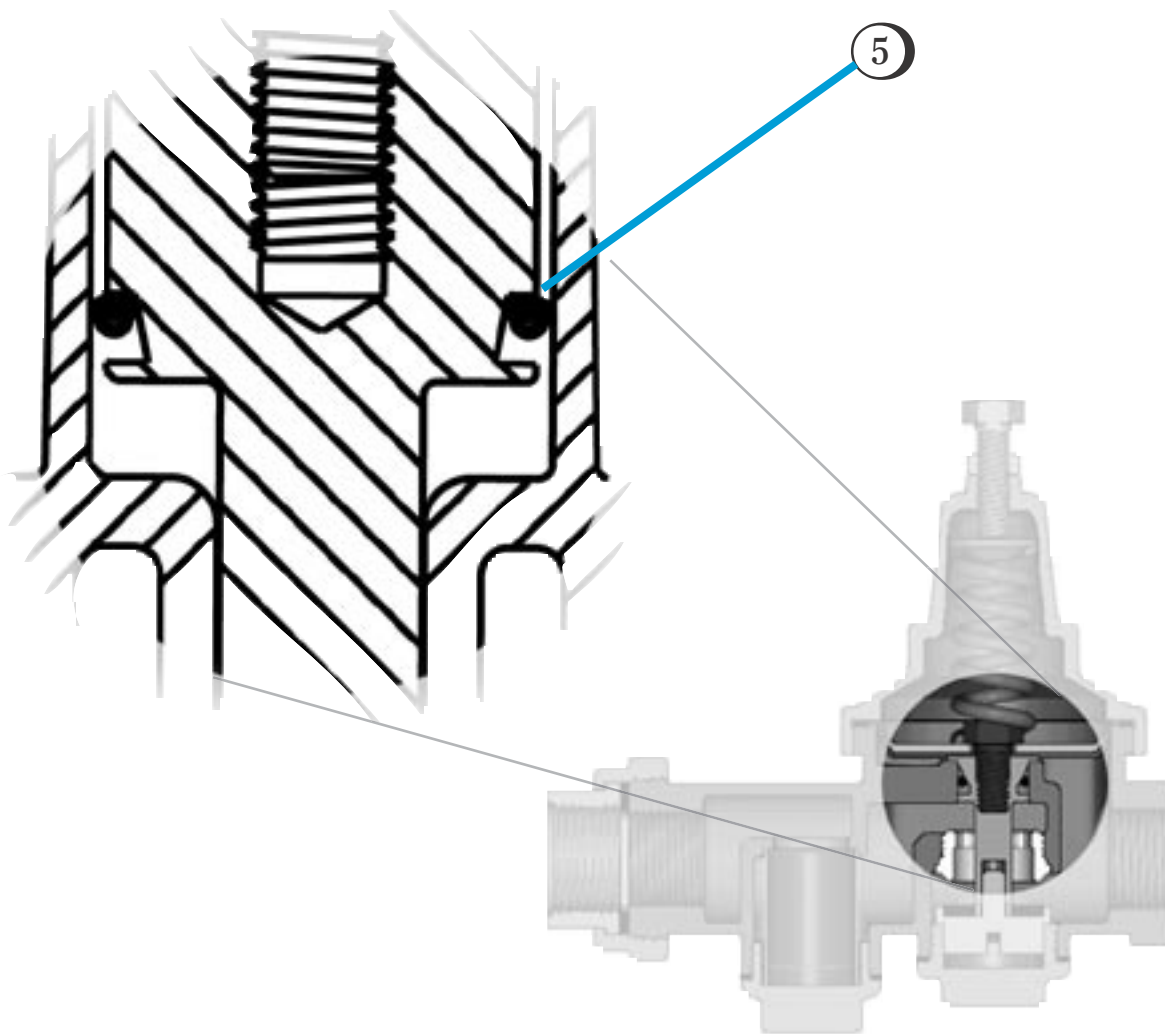

WILKINS is the one name that is synonymous with quality in the manufacture of Pressure Reducing Valves for water. Specialists in the production of Pressure Reducing Valves, WILKINS test every valve under conditions far more severe than will ever be encountered in the field. This is your assurance that when you buy, specify or install WILKINS Pressure Reducing Valves you are selecting the most reliable regulator in the industry.

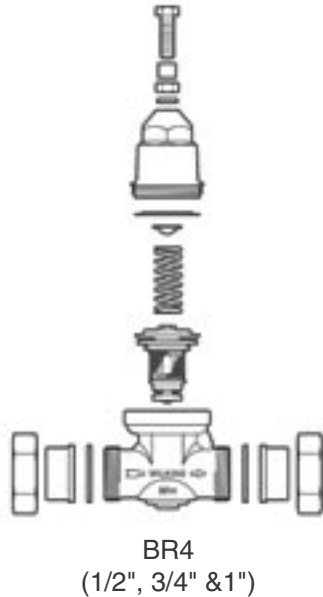

WILKINS is the acknowledged leader in today's market in creating technical advances to produce a product consistent with the needs of every facet of our industry. WILKINS Pressure Reducing Valves are made to meet the exact needs of residential, commercial, industrial, fire protection, irrigation and marine applications.

Features Include:

ALL BRONZE CONSTRUCTION. By using an all bronze construction the potential for electrolytic corrosion is eliminated. Electrolytic corrosion occurs when two dissimilar metals are joined and react to each other (Model BR4 utilizes a composite bell).

THREADED CONNECTION OF BELL HOUSING TO BODY. Provides easier access to the spring, diaphragm, screen or plunger if service is needed. Eliminates screws that can corrode.

HEX ON BELL. Provides greater flexibility in installation and access without special tools.

STAINLESS STEEL SCREEN. Provides a long-wearing material to eliminate fouling.

NYLON REINFORCED BUNA-N DIAPHRAGM. Provides superior strength.

STAINLESS STEEL OR COMPOSITE SEAT. Provides greater resistance and durability, over a long period of time, to wear caused by wire drawing.

PATENTED O-RING BYPASS. Bypass prevents a closed system. Helps eliminate the problems associated with thermal expansion. The WILKINS bypass meets and exceeds the requirements of A.S.S.E.

UNION END. A union end connection is available on all WILKINS regulators through 2". Some regulators are available with unions on both ends.

COMPLIES with all major code agencies including the Uniform Plumbing Code, National Plumbing Code, Federal Housing Administration, American Society of Sanitary Engineers, Canadian Standards Association and major city codes.

EVERY VALVE IS HYDROSTATICALLY TESTED at the factory under conditions far more severe than the valve will see in service. Each valve is tested at the extreme end of the spring range and factory set.

ORIENTATION. Can be installed in both bell up or bell down orientation.

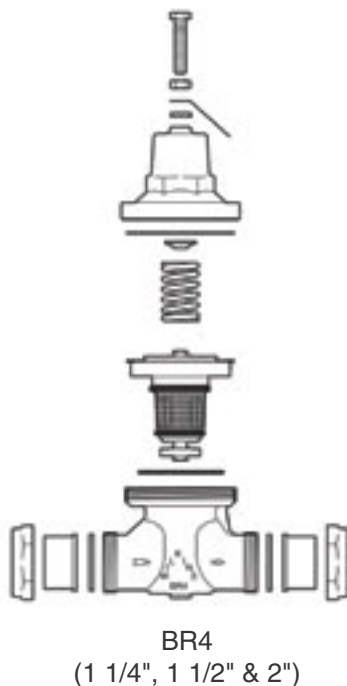

1.

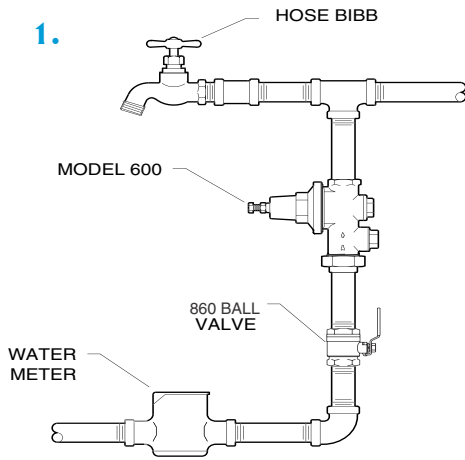

2.

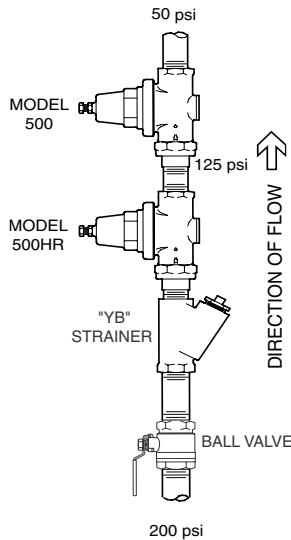

3.

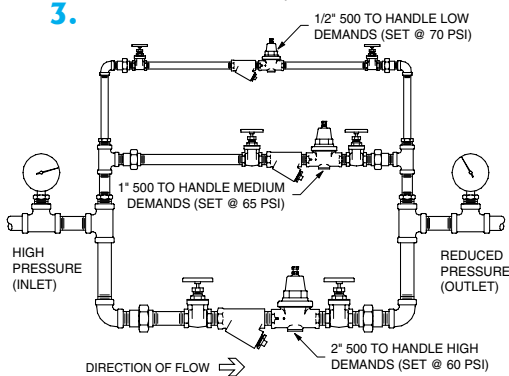

4.

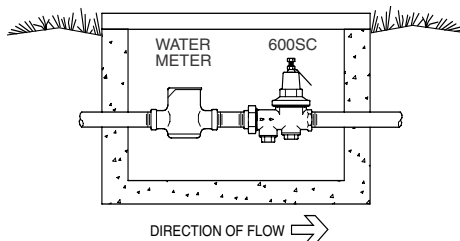

1. SINGLE REGULATOR AND SIZING – The normal installation on residential and small commercial applications is the single regulator. This installation requires that the regulator handle all demand flows from zero to full capacity.

2. MULTIPLE REGULATOR INSTALLATIONS – TWO REGULATORS IN SERIES: This type of installation used in special situations in which a wide variance between the inlet pressure and the desired reduced pressure exists. Series application is generally recommended when there is a wide fluctuation of inlet pressure or where the desired pressure reduction is more than 4 to 1 (i.e.:200 psi to 50 psi).

3. PARALLEL INSTALLATIONS - MULTIPLE REGULATORS IN PARALLEL: In many instances a battery installation is preferable to the use of a single valve, as it provides closer regulation over a wide demand variation.

This type of installation consists of a group of parallel regulators, all receiving water from a common supply main. After flowing through the battery of valves, water enters a common service line of sufficient size to service the system at the reduced pressure. The battery installation is advantageous because it allows maintenance work to be performed without the necessity of turning off the entire system. It also gives better performance where demands vary from one extreme to another.

For example, at a school with a 3" service, the demand by drinking fountains during classes may be approximately 6 to 7 GPM. However, between classes, when all services are in use, the demand may be at maximum. With a single 3" regulator in the system, when a fountain is turned on, the regulator must open to allow a small draw. Each time this is done, it is cutting down on the service life of the large regulator.

In comparison, with a battery installation of two or three regulators set at graduated pressure, with the smallest valve set 3 to 5 PSI higher than the larger ones, the system would be more efficient. For small demand, only the smallest valve would open. As the demand increased, the larger valves would also open, thus providing the system with the capacity of all the valves in the battery.

4. PIT INSTALLATIONS – This type of installation is used in special situations in which a pressure reducing valve is installed below ground or in corrosive environments. The SC option (BR4SC, 70SC, 500SC, and 600SC) includes a sealed cage bell, stainless steel adjusting bolt and locknut. This design protects the dry side of the regulator by maintaining a water tight seal within the bell housing. The stainless steel adjusting bolt and locknut provide maximum resistance to corrosion. The SC option is also recommended for indoor applications.

valve **SELECTION AND SIZING**

The selection of the correct type of regulator depends entirely on the accuracy of the regulation required.

The Best Way

The only truly sound valve selection procedure to follow is to capacity size a valve on the basis of known performance data related to system requirements. The amount of water that a regulator must flow is determined by the flow required for the valve application in gallons per minute, and the required delivery pressure in psi. Additionally, the tolerable Fall-off that the system can withstand must be considered.

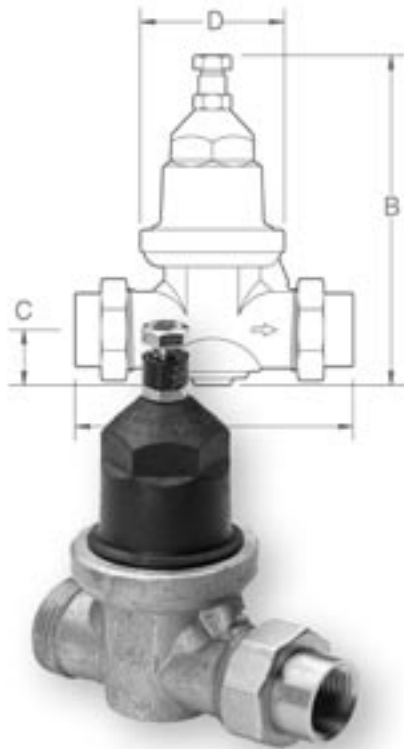

BR4

Reduced pressure change that occurs when a valve opens is known as Fall-off. Reduced Pressure Fall-off is the difference between the static pressure and the residual or flowing pressure downstream of the regulator. Fall-off is an inherent characteristic of all direct acting regulators and is an important factor when selecting the proper valve size and type. Fall-off is used to predict the valve capacity in Gallons per Minute.

By putting this data together it can be seen that three pieces of information are needed to properly size a regulator. These pieces of information are:

- Flow required for the application in Gallons per Minute (GPM)
- Delivery pressure of the water in Pounds per Square Inch (PSI)
- The maximum allowable difference between downstream flowing pressure and static pressure or the Fall-off.

The Other Ways

Some installers/designers may think they are doing their client a favor by over-sizing the valve but this is simply not true. For example, using a 2" valve because it will be twice as good as using a 1" valve, will lead to rapid failure of the 2" valve. The valve plunger in oversized valves tends to remain close to the seat in low flow conditions, causing wire draw and excessive wear. Under sizing the regulator can have the same consequences. Under sizing causes very high flowing velocity, which will cause noise and wear of the internal components.

Capacity rating of a pressure reducing valve is usually expressed in terms of some single value. This value, to be useful, must specify all the conditions under which the rating was established, otherwise it is impossible to factually adapt it to system conditions. Set pressure and allowable reduced pressure fall-off of 15 to 17 psi is considered reasonable for the average residential installation and, in well designed valves, will produce a good rating. For Commercial and Industrial applications, allowable Fall-off is usually much more critical. Therefore, a standard allowable Fall-off cannot be given. It must be reviewed on a case by case basis.



HGI-25 Pressure Gauge with high pressure indicating needle and hose bibb connection.

Another procedure for establishing valve performance is on the basis of rate of flow, with a reduced pressure fall-off of 15 to 17 psi below reduced lock-up or no flow pressure. For general use, this approach provides an adequate means for valve selection. It is not, however, specific enough to enable the selection of a valve best suited to specific conditions.

Many manufacturers rate their valves on the basis of a stipulated flow rate at a specific pressure differential, with the valve open to atmosphere, without regard to change in pressure when the system demand is zero. This method does not provide ample information for proper judgement of valve behavior and capability, and could result in the selection of a valve that would, under no-demand conditions, permit a reduction in pressure great enough to damage equipment in the system...ie. The Fall-off at the indicated flow rate was too high resulting in unacceptably high static pressure.

Maximum pressure permitted in a system under no flow conditions is an important design factor, both for physical and economic reasons, and should be stipulated in the specifications.

The rule of thumb method frequently employed is a size to size selection. This is using a valve having the same connection sizes as the pipeline in which it is to be installed. This is a gamble, because the actual capacities of many valves are inadequate to satisfy the service demand specified for a pipeline of corresponding size.

Thermal Expansion

THE PROBLEM

Leaky faucets, broken hoses, drippy water heater relief valves and excessive water pressure surges causing “water hammer”. All these aggravations can be caused by thermal expansion.

Many of these problems are a result of increasingly common code regulations that require backflow preventers to be placed between the public and private water supplies. Simply put, in a closed system, excessive pressure occurs in the hot water lines when the thermally expanded water has no escape route, causing a variety of symptoms that can lead to serious plumbing problems.

In a Thermal Expansion condition, the pressure build-up occurs as the heated water expands in volume. If the utilized pressure regulator has a bypass feature and the service pressure, on the upstream side of the regulator is less than 150 PSI, the expanded water pressure is dissipated back to the city service main. Thus, the integral by-pass will maintain equilibrium, thereby preventing the downstream pressure from exceeding the upstream pressure and precluding Temperature & Pressure Relief Valve discharge.

If, however, the inlet pressure to the pressure regulator is greater than or equal to 150 PSI, the Temperature & Pressure Relief Valve will discharge into the atmosphere before the integral by-pass will operate.

The Solution

Wilkins has several simple solutions to the Thermal Expansion problem.

The first is to install a Relief Valve for the control of Thermal Expansion in the plumbing system. From the Wilkins Models P1520 and P1550 fixed setting Pressure Relief Valves to the Model BVEC Water Heater Shut-Off Valve with integral Thermal Expansion Relief Valve. The Model BVEC is a Full Port Bronze Ball Valve designed for residential water heater applications where a water heater shut-off and thermal expansion relief valve are combined to provide protection from thermal expansion.

Because the BVEC thermal expansion relief valve is designed to relieve pressure periodically as the water heats, it will discharge approximately 1/3 of a gallon of water (on a 40 gallon water heater) during a reheat cycle. While effective, the disadvantage of using the BVEC is that a discharge line must be connected to the relief valve outlet and directed to a safe disposal drain.

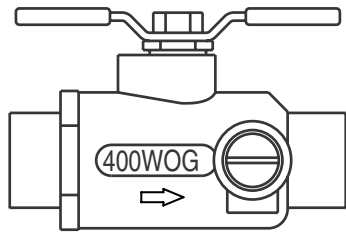
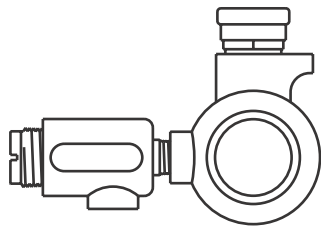

BVEC

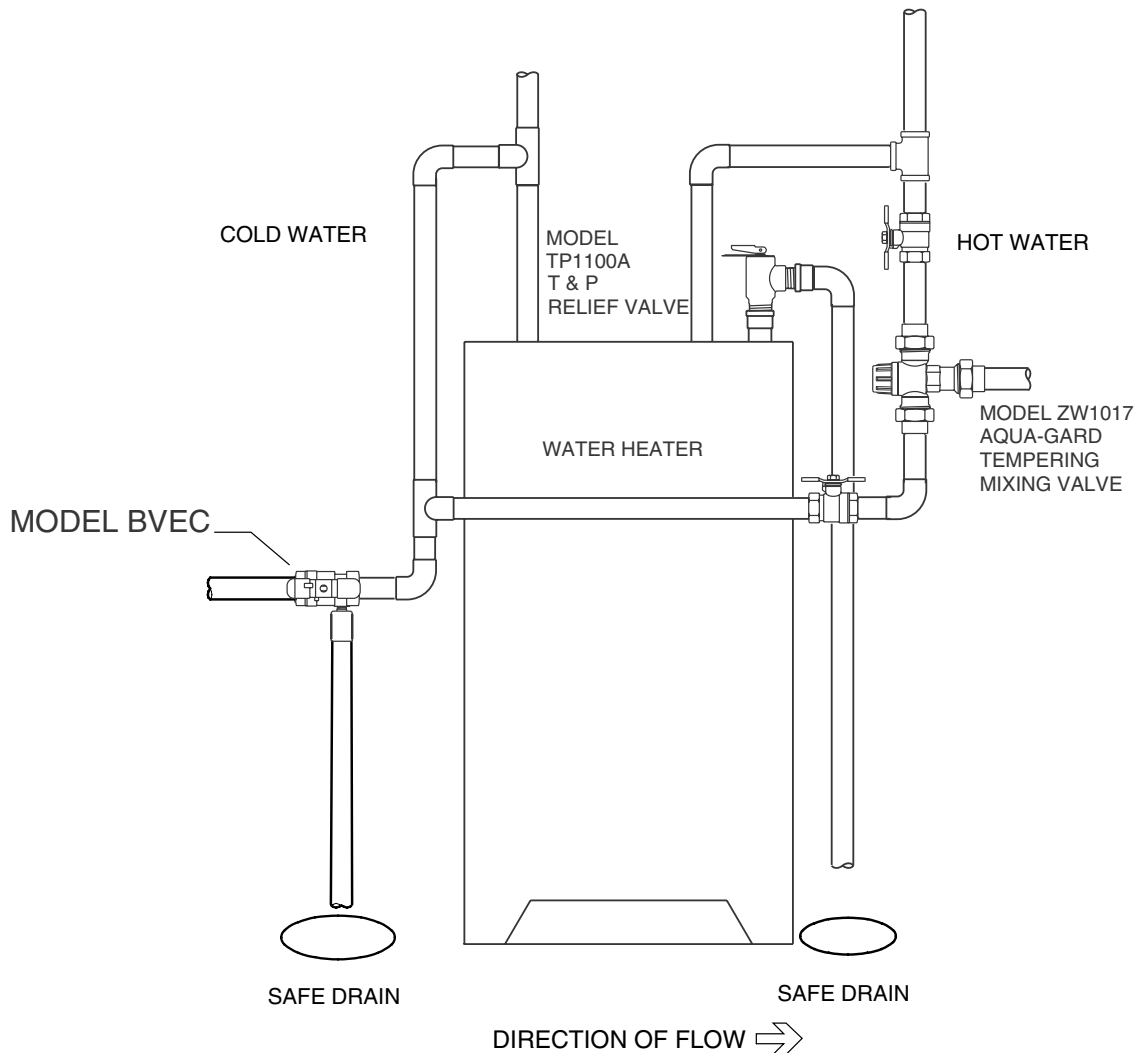

A better solution to thermal expansion is to install a Wilkins Thermal Expansion Tank to the plumbing system. The use of a water Thermal Expansion Tank (WILKINS Model WXTP) is to accommodate the additional water volume and prevent discharge from the Temperature & Pressure Relief Valve. The Thermal Expansion Tank accepts the expanded volume of water until it can be utilized

back into the system. As water temperature rises in the water heater, expanded water enters the Thermal Expansion Tank's water reservoir. The pre charged air chamber absorbs the pressure increase, maintaining system pressure at a point below the Temperature & Pressure Relief Valve opening point. When water is used, the pressure in the air chamber forces the water back into the system until it once again equals the supply pressure.

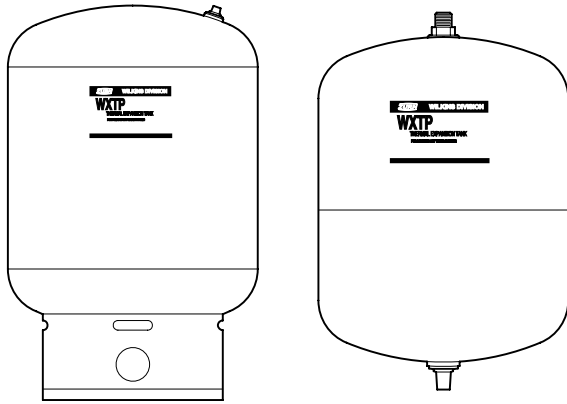

Selecting a properly sized Thermal Expansion Tank is critical in the reduction of pressure fluctuations in the system and is determined by both supply pressure and water heater capacity. The tank must be installed in the cold water supply side between the backflow preventer or the pressure regulating valve and the hot water heater.

Installation of the thermal expansion tank has proven to be the most effective coded solution for the problem of thermal expansion.

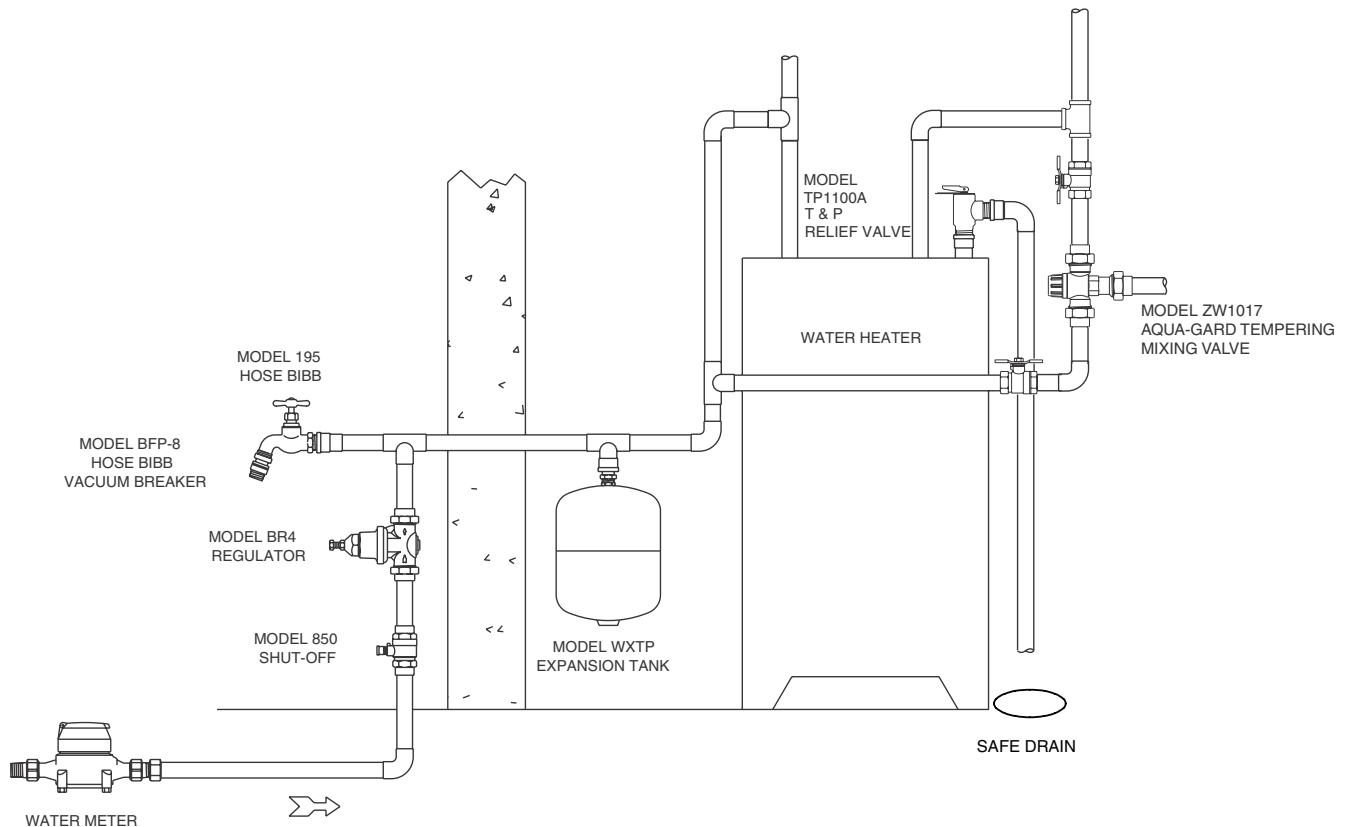

PERFORMANCE CURVES

Performance curves are provided for each model and size of WILKINS Regulators.

EXAMPLE

REQUIREMENT:

Select proper size valve

GIVEN:

Initial Pressure : 110 psi
 Reduced no-flow pressure: 50 psi
 Demand: 20 gallons per minute
 Allowable fall-off: 12 to 17 psi

PROCEDURE:

On the chart, locate 20 gallons per minute on the bottom line and move up until it intersects the last valve size curve that is within the given allowable fall-off parameters of 12 to 17 psi. In this case the 3/4" size provides design capacity at a fall-off of 14 psi, well below the allowable fall-off requirement.

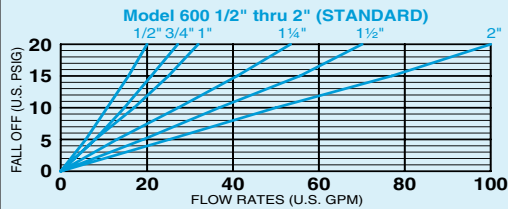

The flow charts for all of the valves are shown on the basis of rate of flow against the reduced pressure Fall-off where pressure Fall-off is defined as the difference between the downstream set static pressure and the flowing water pressure.

The zero (0) on the Fall-off column represents the reduced pressure setting of the regulator when there is no flow, commonly called the reduced lock-up pressure. It can be any setting within the adjustment range of the regulator. The figures above the zero (0) show the fall-off or pressure change that is necessary to produce the flows indicated by the curves of various size valves. It should be noted that the curves terminate with a maximum Fall-off of 20 PSI. Exceeding a 20 PSI Fall-off is not recommended because high velocity resulting in noise and rapid wear of the Pressure Reducing Valve will result. When a Fall-off greater than 20 PSI will occur, one should step up to the next larger Regulator.

The difference between the incoming pressure and the reduced lock-up pressure has little effect upon the capacity of the valve except when the difference is less than 50 psi. When this occurs, the capacity of the valve is somewhat limited and a small compensation must be made in the sizing selection. To compensate for this condition, deduct 20 percent from the capacity shown. The following examples are given to assist in the procedure of using the charts to determine size and capacities in the selection process.

EXAMPLE

REQUIREMENT:

Determine the flow capacity

GIVEN:

1 1/4" Model 600 Valve

PROCEDURE:

On the chart, find the intersection of the 1 1/4" size curve and the 20 psi fall-off line. Moving down from this intersection to the flow rate line, the capacity of 53 gpm is indicated.

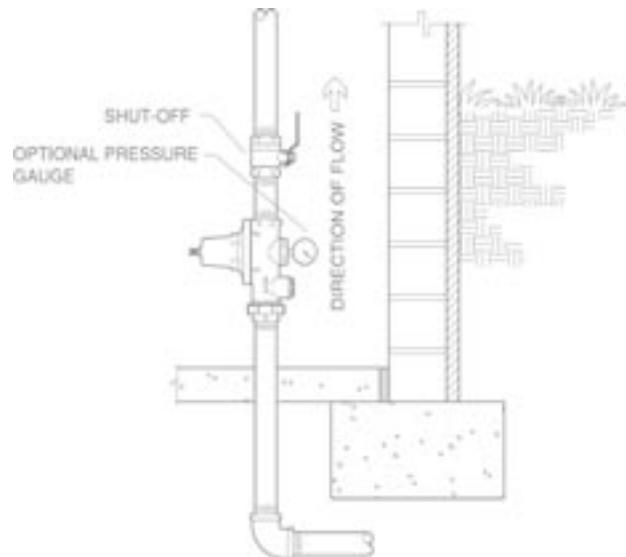
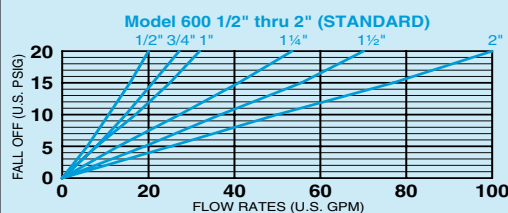

SELECTING THE RIGHT WILKINS REGULATOR

Model BR4 1/2" - 1"



Water Pressure Reducing Valve with Integral By-pass Check Valve

- Maximum working water pressure 400psi
- Reduced pressure range 15 to 150psi, factory set to 50psi
- Includes corrosion-resistant drop-in acetal replacement cartridge with integral stainless steel strainer
- Repair kits readily available

Model BR4 1 1/4"-2"



Water Pressure Reducing Valve with Integral By-pass Check Valve

- Maximum working pressure 400psi
- Spring range gives downstream adjustment capability of 15-75psi, factory set at 50psi
- All bronze body and bell housing

Model BR4EC



Water Pressure Reducing Valve with Integral By-pass Check Valve and Thermal Expansion Control Valve

- Sizes: 1/2", 3/4", 1"
- Reduced pressure range 15psi to 100psi, factory preset to 55psi
- Includes expansion valve allowing excessive downstream pressure caused by thermal expansion to be vented to a safe disposal

Model BR5



Stainless Steel Water Pressure Reducing Valve with Integral By-pass Check Valve

- Sizes: 3/4", 1"
- Suitable for water systems that require corrosion resistance to mildly corrosive fluids, as well as applications requiring minimal trace elements of lead.
 - Body is furnished with 300 series stainless steel, while the internal components use a low lead brass material

Model 70



Water Pressure Reducing Valve with Integral By-pass Check Valve

- Sizes 1/2", 3/4", 1", 1 1/4", 1 1/2", 2"
- Pressure rated at 300psi
- Replaceable cartridge reduces time involved with cleaning and maintenance
- The direct acting integral by-pass design prevents buildup of excessive system pressure caused by thermal expansion.

Model 600



Water Pressure Reducing Valve with Integral By-pass Check Valve and Strainer

- Sizes: 1/2", 3/4", 1", 1 1/4", 1 1/2", 2"
- Recommended for residential and commercial applications where easy accessibility to an internal strainer screen is necessary.
- Integral stainless steel strainer with separate access cover
- Replaceable stainless steel seat
- All internal parts corrosion-resistant

Model 500



Water Pressure Reducing Valve with Integral By-pass Check Valve

- Sizes: 1/2" thru 3"
- Reduced pressure range 25psi to 75psi, factory set at 50psi
- Recommended for industrial water lines and commercial irrigation systems
- High flow capacity

Model 500YSBR



Water Pressure Reducing Valve with Integral By-pass Check Valve

- All of the great features of the model 500, plus an in-line bronze "Y" type strainer with 20 mesh stainless steel screen
- Recommended for commercial installations where debris is prevalent in the water system

Model 500FC



Water Pressure Reducing Valve with Flanged Connections

- Sizes: 2", 2 1/2", 3"
- Comes with flanged connections
- Recommended for commercial and industrial applications
- Spring range 25 to 75psi, factory set at 50psi
- High flow capacity

Model 80



Boiler Regulator with Quick Fill/Purge Lever

- Sizes: 1/2" thru 3/4"
- Recommended for installation on hydronic heating systems to reduce the inlet pressures to a lower reduced pressure
 - Reduced pressure range 10psi to 25 psi, factory set at 15psi
 - All bronze body and bell, equipped with a Quick Fill/Purge lever, capable of feeding and purging of boiler feed lines.
 - Built-in check valve maintains a positive seal which prevents reverse water flow

Model 90



Water Pressure Reducing Valve

- Sizes 3/4", 1"
- Pressure adjustment range (0-50psi) makes the Model 90 most suitable to drip irrigation systems requiring lower operating pressures

FOR THE RIGHT APPLICATION

Residential **Light Commercial** **Commercial** **Industrial**

BR4 1/2"-1"			
BR4 1-1/4"-2"			
BR4EC			
	BR5		
Model 70			
Model 600			
	Model 500		
	Model 500YSBR		
	Model 500FC		
	Model 80		
Model 90			

PERFORMANCE CURVES For Wilkins Pressure Regulators

MODEL BR4/EC

1/2", 3/4", 1"

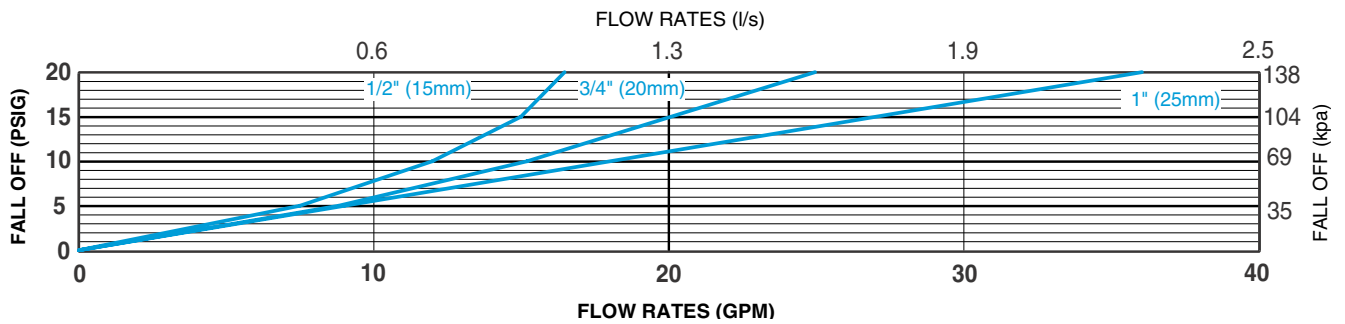

MODEL BR4

1 1/4", 1 1/2", 2"

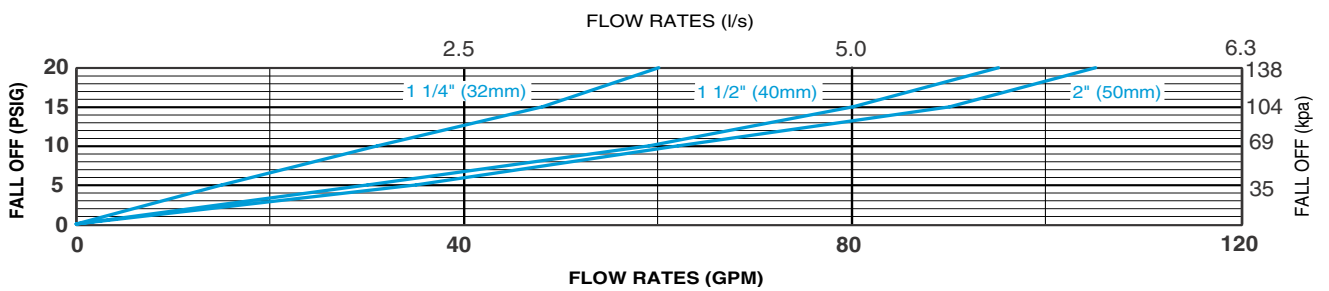

MODEL BR5/BR5ST

3/4", 1"

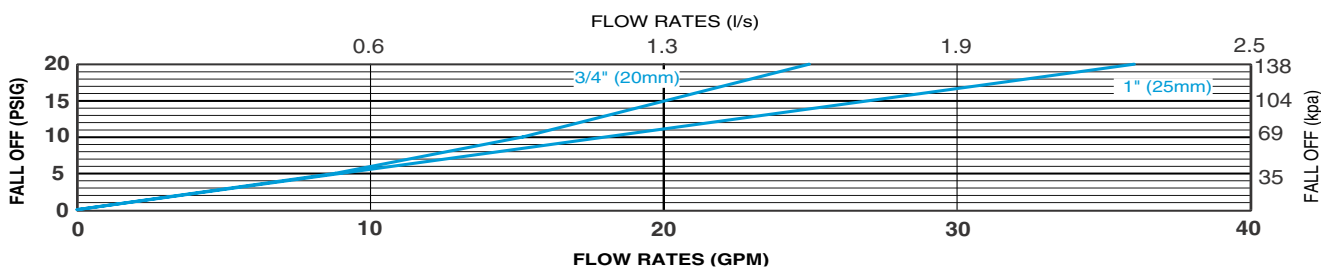

MODEL 70/70DU

1/2", 3/4", 1", 1 1/4", 1 1/2", 2"

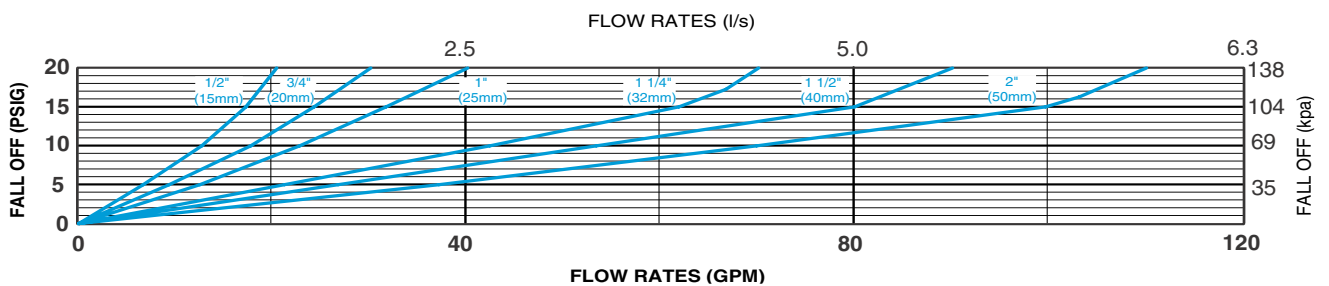

MODEL 80

1/2", 3/4"

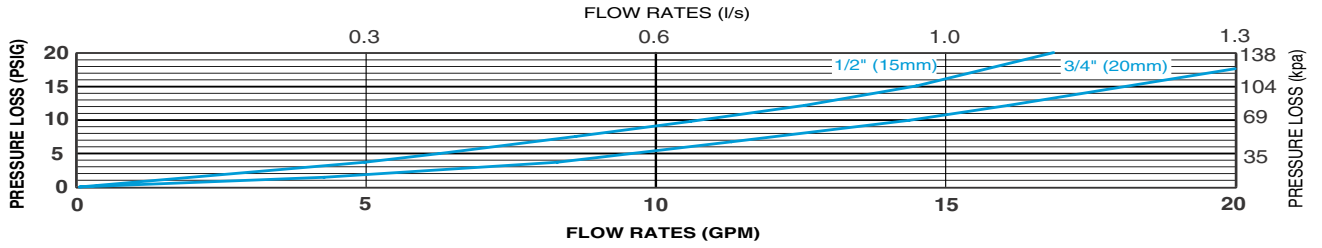

MODEL 90

3/4", 1"

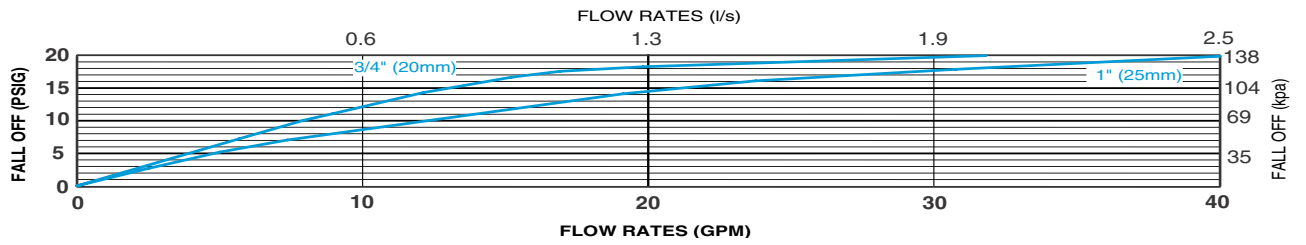

MODEL 500

1/2", 3/4", 1", 1 1/4", 1 1/2", 2", 2 1/2", 3"

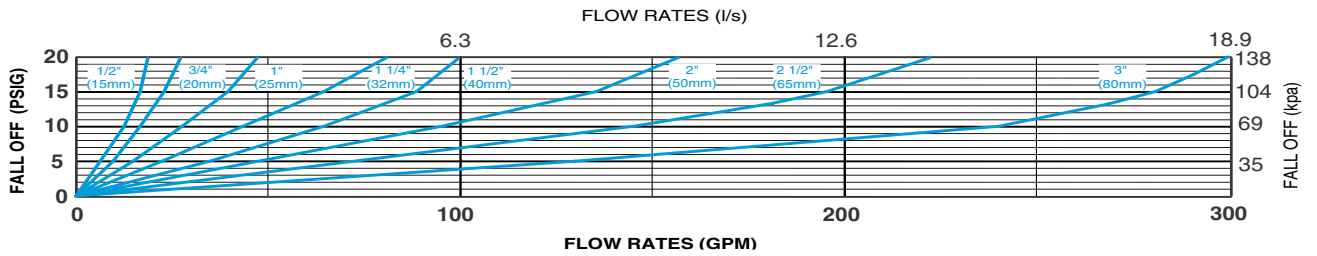

MODEL 500YSBR

1/2", 3/4", 1", 1 1/4", 1 1/2", 2", 2 1/2", 3"

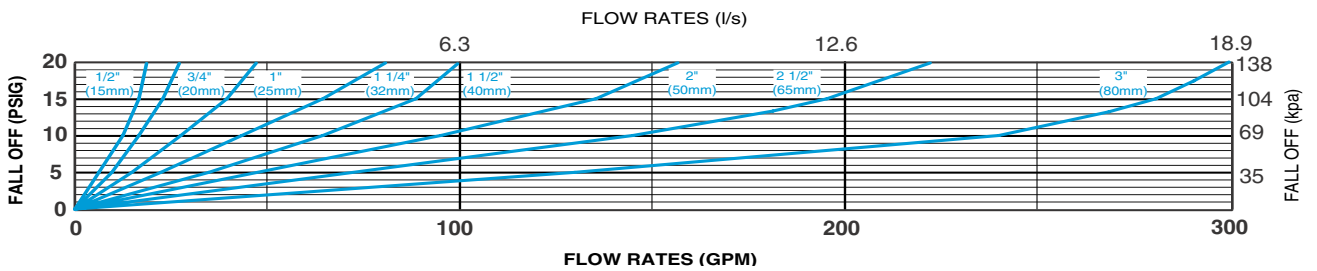

MODEL 500FC & 500FCBP

2", 2 1/2", 3"

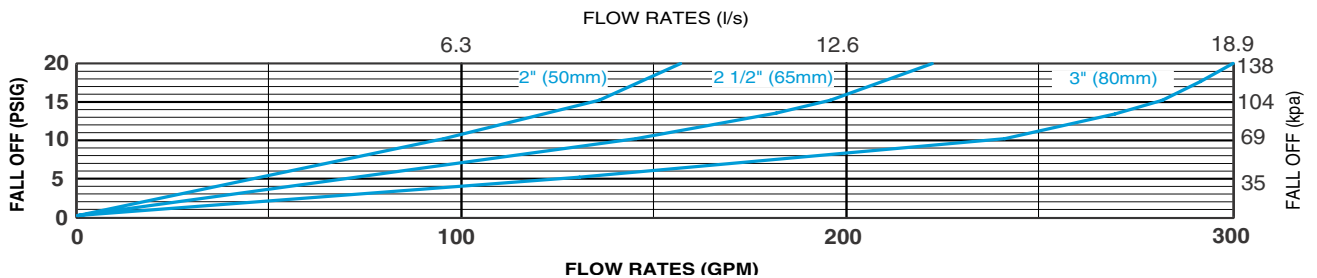

MODEL 600

1/2", 3/4", 1", 1 1/4", 1 1/2", 2"

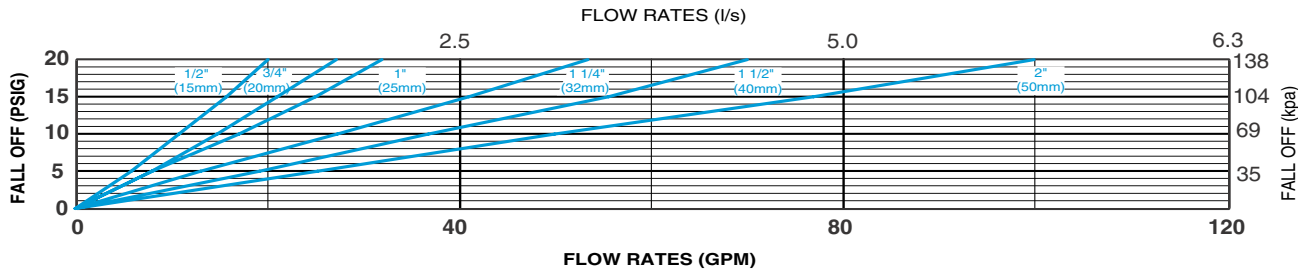
**MODEL 600DM**

3/4"

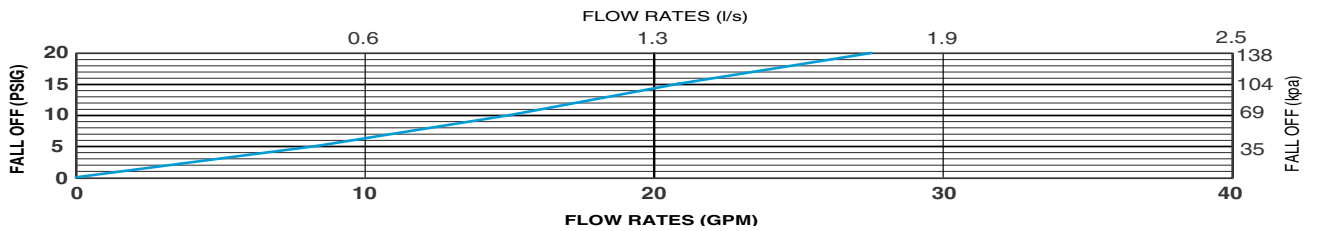

Pressure Regulators help in Water Conservation. Reducing water pressure from 100 to 50 psi results in a 33% water savings and cuts wastewater by 1/3rd.

Water systems can be viewed like an electrical system. Overhead transmission lines at the street carry 21,000 volts. This high voltage is sent through a transformer that reduces the volts to 120. This is done for safety and conservation purposes.

TYPICAL INSTALLATIONS For Wilkins Pressure Regulators

Model BR4/BR4EC

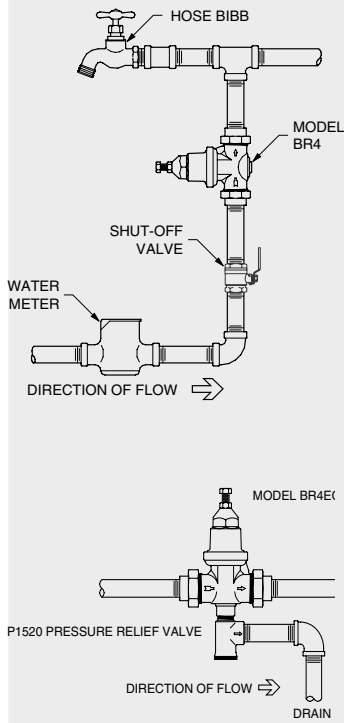

Model 70

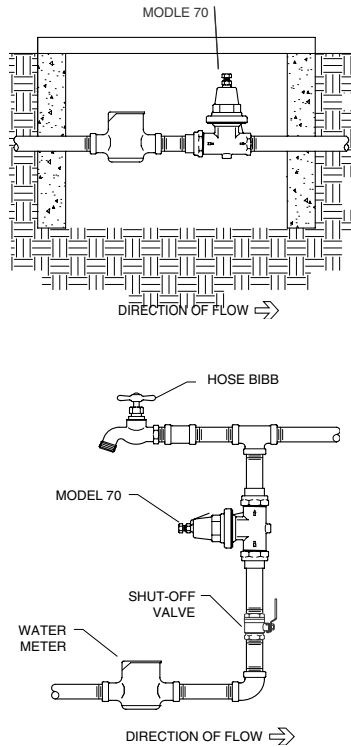

Model 70DU

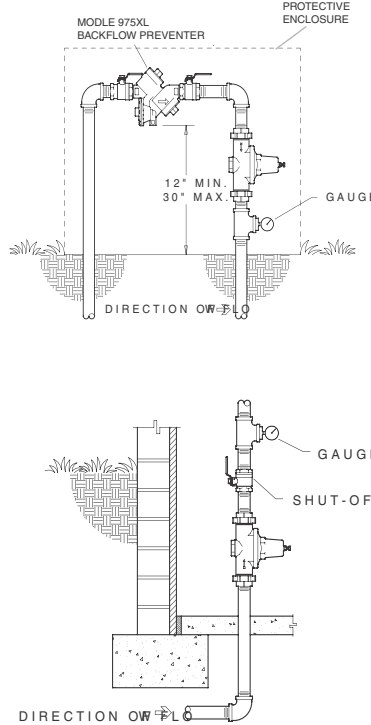

Model 600

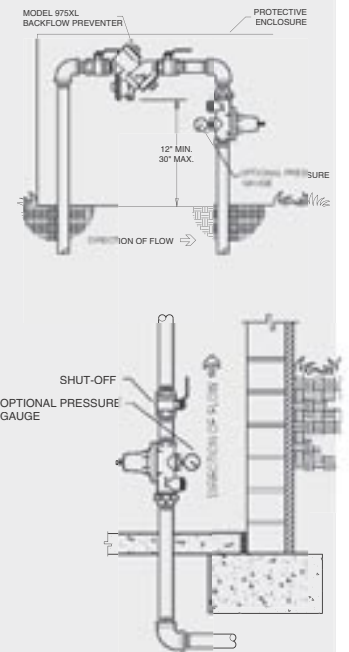

Model 500/500FC

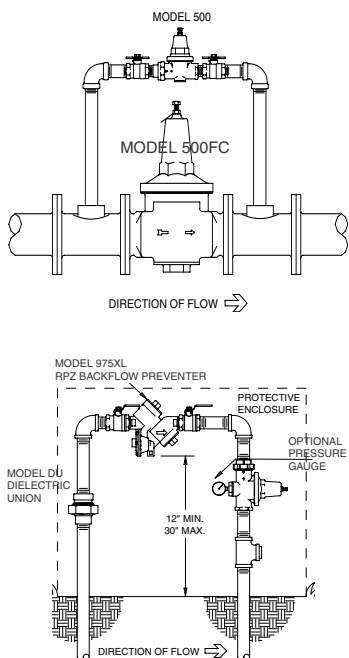

Model 500YSBR

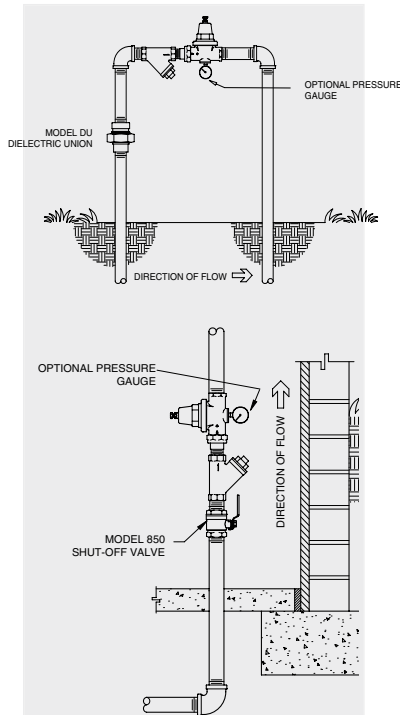

Model 80

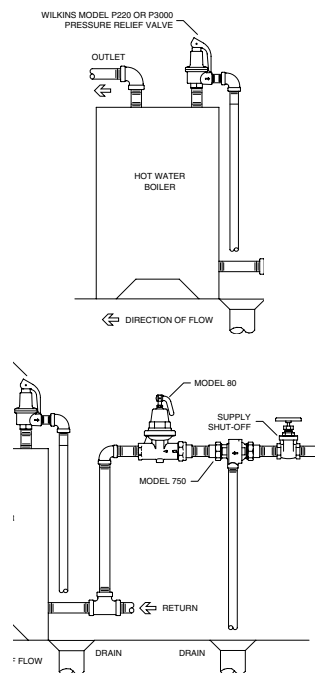

Model 90

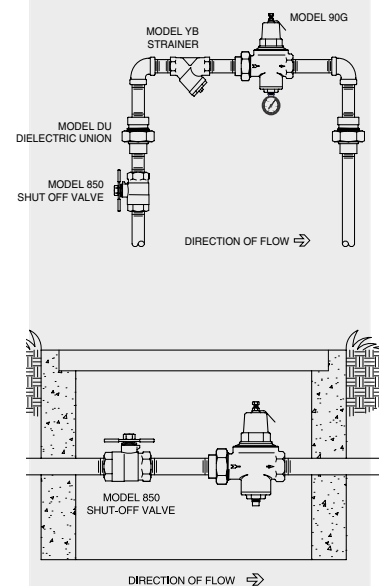

TROUBLESHOOTING

Wilkins Pressure Regulators

Pipe lines in a water supply system must be of sufficient carrying capacity to maintain adequate pressure at the most remote or highest fixture. Under the maximum probable fixture use, minimum adequate pressure is generally 8 to 15 lbs. but may be more, depending on the equipment being supplied. Relatively high service pressures which can create high water velocities in pipe lines would allow use of smaller pipes to satisfy fixture use. However, high velocity tends to cause whistling and humming. Reduction of pressure by the use of a pressure reducing valve, in an attempt to eliminate such a condi-

tion, may reduce pipe line capacities below that which is adequate for maximum probable use. When high service pressures are in effect, either continuously or periodically, the application of a pressure reducing valve will be successful only when the installed pipe line is of adequate size to satisfy the system demand at the lower pressure. When actual water demands are unknown, the valve size should be no less than the existing pipe size.

PROBLEM

1. Pressure creeps or builds up in system above the setting of pressure reducing valve.

POSSIBLE CAUSE OR CAUSES

- A. Thermal expansion of water as it is being heated.
- B. Foreign matter on seating face of seal ring.
- C. Cut, worn or chipped seal ring.
- D. Cut or worn stem o-ring or worn o-ring groove.

SOLUTION

- a. This is a natural consequence. It may happen each time that the heater runs. A pressure relief valve or expansion tank must be installed. This will not prevent pressure rise but should limit it to a safe level.
- b. Flush the reducing valve by opening one or two fixture outlets wide. If this does not correct the problem, remove seal ring for cleaning.
- c. Replace with new seal ring. Temporary repairs may be made by turning the seal ring over.
- d. Replace with new stem o-ring and/or cartridge.

2. Pressure and fixture flow is unsteady.

- A. Low water supply pressure in mains caused possibly by high area demand during certain periods of the day.
- B. Heavy periodic demands by appliances in the house.

SOLUTION

- a. This is a water department problem. It is due to the mains being inadequate for the demands made on them.
- b. House service lines may at times be inadequate for the load. Size of some pipelines may need to be increased. Pressure setting of reducing valve may be too low.
- c. Try increasing pressure before changing pipelines.

3. Small, inadequate flow from fixtures.

- A. Pipelines to fixtures may be too small or house main supply may be inadequate for normal fixture demand.
- B. Heavy periodic demands by appliances in the house.
- C. Screen clogged with debris.

SOLUTION

- a. It may be necessary to increase pipe sizes only in some sections of the system leading to the offending appliances or fixtures. Increasing the house service mains might be necessary if small supply is general at all fixtures.
- b. Raise pressure gradually by readjusting valve until this point is determined.
- c. Clean screen.

4. Valve appears to be noisy; hums, whistles or chatters.

- A. Hum or whistle is usually caused by a high velocity of flow in pipelines causing vibration.
- B. Chatter usually originates with worn seat washer or loosely installed seal ring.

SOLUTION

- a. Pipelines could be small or too light. Reducing valves could be too small. Pipes and valves being small would accentuate this condition.
- b. Inspect seal ring. If a deep channel appears on seal ring face, replace or use the opposite side.
- c. Frequently noise appears in a faucet or appliance and seems to originate from the reducing valve. There is a general tendency to use streamline piping of a relatively small size. Velocity is naturally high and noise of fast moving water is not unusual.

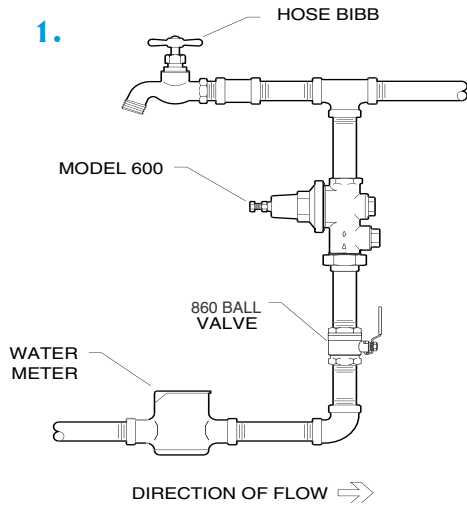

1. SINGLE REGULATOR AND SIZING – The normal installation on residential and small commercial applications is the single regulator. This installation requires that the regulator handle all demand flows from zero to full capacity.

2. PIT INSTALLATIONS – This type of installation is used in special situations in which a pressure reducing valve is installed below ground or in corrosive environments. The SC option (BR4SC, 70SC, 500SC, and 600SC) includes a sealed cage bell, stainless steel adjusting bolt and locknut. This design protects the dry side of the regulator by maintaining a water tight seal within the bell housing. The stainless steel adjusting bolt and locknut provide maximum resistance to corrosion. The SC option is also recommended for indoor applications.

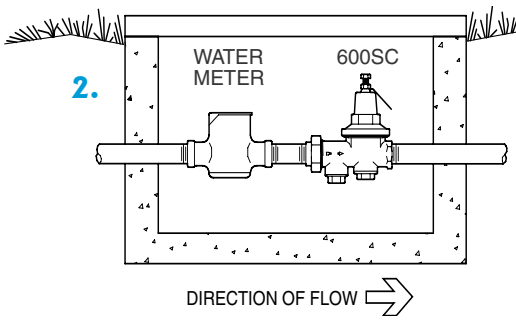

3. MULTIPLE REGULATOR INSTALLATIONS – TWO REGULATORS IN SERIES: This type of installation used in special situations in which a wide variance between the inlet pressure and the desired reduced pressure exists. Series application is generally recommended when there is a wide fluctuation of inlet pressure or where the desired pressure reduction is more than 4 to 1 (i.e.:200 psi to 50 psi).

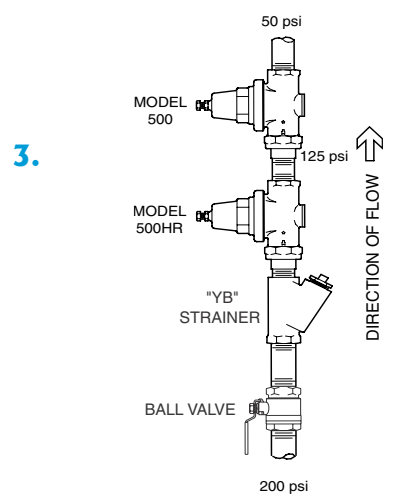

4. PARALLEL INSTALLATIONS - MULTIPLE REGULATORS IN PARALLEL: In many instances a battery installation is preferable to the use of a single valve, as it provides closer regulation over a wide demand variation.

This type of installation consists of a group of parallel regulators, all receiving water from a common supply main. After flowing through the battery of valves, water enters a common service line of sufficient size to service the system at the reduced pressure. The battery installation is advantageous because it allows maintenance work to be performed without the necessity of turning off the entire system. It also gives better performance where demands vary from one extreme to another.

For example, at a school with a 3" service, the demand by drinking fountains during classes may be approximately 6 to 7 GPM. However, between classes, when all services are in use, the demand may be at maximum. With a single 3" regulator in the system, when a fountain is turned on, the regulator must open to allow a small draw. Each time this is done, it is cutting down on the service life of the large regulator.

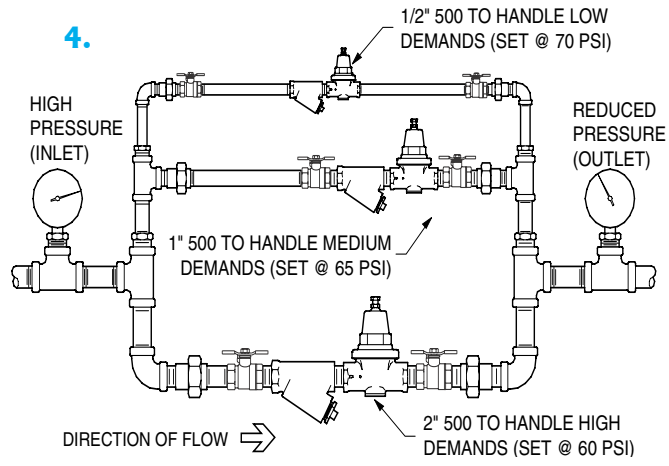

In comparison, with a battery installation of two or three regulators set at graduated pressure, with the smallest valve set 3 to 5 PSI higher than the larger ones, the system would be more efficient. For small demand, only the smallest valve would open. As the demand increased, the larger valves would also open, thus providing the system with the capacity of all the valves in the battery.



WILKINS
 a **ZURN** company

1747 Commerce Way, Paso Robles, CA 93446
 Phone: 805•238•7100 Fax: 805•238•5766

3544 Nashua Drive,
 Mississauga, Ontario Canada 4V1L2
 Phone: 905•405•8272 Fax: 905•405•1292

www.zurn.com

