

**JOINT APPLICATION OF  
LCRA TRANSMISSION SERVICES CORPORATION  
AND AEP TEXAS INC TO AMEND THEIR  
CERTIFICATES OF CONVENIENCE AND  
NECESSITY FOR THE PROPOSED BAKERSFIELD  
TO SOLSTICE 345-KV TRANSMISSION LINE  
PROJECT IN PECOS COUNTY, TEXAS**

**DOCKET NO. 48787**

*Submit seven (7) copies of the application and all attachments supporting the application. If the application is being filed pursuant to 16 Tex. Admin. Code § 25.101(b)(3)(D) (TAC) or 16 TAC § 25.174, include in the application all direct testimony. The application and other necessary documents shall be submitted to:*

**Public Utility Commission of Texas**

**Attn: Filing Clerk**

**1701 N. Congress Ave.**

**Austin, Texas 78711-3326**

**JOINT APPLICATION OF LCRA TRANSMISSION SERVICES CORPORATION AND AEP TEXAS INC  
TO AMEND THEIR CERTIFICATES OF CONVENIENCE AND NECESSITY FOR THE PROPOSED  
BAKERSFIELD TO SOLSTICE 345-KV TRANSMISSION LINE PROJECT IN PECOS COUNTY, TEXAS**

---

Applicants LCRA Transmission Services Corporation (LCRA TSC) and AEP Texas Inc. (AEP Texas) are filing this application as Joint Applicants and request that all parties serve copies of all pleadings, discovery, correspondence, and other documents on the following representatives:

**Service Contacts:**

Kirk Rasmussen  
State Bar No. 24013374  
Enoch Keever PLLC  
5918 W. Courtyard Dr., Suite 500  
Austin, TX 78730  
(512) 615-1203  
[kasmussen@enochkeever.com](mailto:kasmussen@enochkeever.com)  
*Attorney for LCRA TSC*

Jerry Huerta  
State Bar No. 24004709  
AEP Service Corp.  
400 W. 15<sup>th</sup> Street, Suite 1520  
Austin, Texas 78701  
(512) 481-3323  
[jnhuerta@aep.com](mailto:jnhuerta@aep.com)  
*Attorney for AEP Texas*

**JOINT APPLICATION OF LCRA TRANSMISSION SERVICES CORPORATION AND AEP TEXAS INC  
TO AMEND THEIR CERTIFICATES OF CONVENIENCE AND NECESSITY FOR THE BAKERSFIELD  
TO SOLSTICE 345-KV TRANSMISSION LINE PROJECT IN PECOS COUNTY, TEXAS**

---

Note: As used herein, the term “joint application” refers to an application for proposed transmission facilities for which ownership will be divided. All applications for such facilities should be filed jointly by the proposed owners of the facilities.

**1. Applicant (Utility) Name:**

**For Joint applications, provide all information for each applicant.**

Applicant (Utility) Name: LCRA Transmission Services Corporation (LCRA TSC)

Certificate Number: 30110

Street Address: 3700 Lake Austin Boulevard  
Austin, TX 78703

Mailing Address: P.O. Box 220  
Austin, TX 78767-0220

Applicant (Utility) Name: AEP Texas Inc. (AEP Texas)

Certificate Number: 30170<sup>1</sup>

Street Address: 539 North Carancahua  
Corpus Christi, TX 78401

Mailing Address: 539 North Carancahua  
Corpus Christi, TX 78401

**2. Please identify all entities that will hold an ownership interest or an investment interest in the proposed project but which are not subject to the Commission’s jurisdiction.**

**Not applicable.** LCRA TSC and AEP Texas will hold separate 50 percent ownership interests in the Bakersfield to Solstice 345-kV Transmission Line Project. No entity not subject to the Commission’s jurisdiction will hold an ownership or investment interest in the project.

---

<sup>1</sup> Certificate Number 30170 was assigned to AEP Texas North Company, which with AEP Texas Central Company, merged with their immediate parent company AEP Utilities, Inc. effective December 31, 2016. The merger was approved by the Public Utility Commission of Texas on December 1, 2016 in PUC Docket No. 46050; SOAH Docket No. 473-16-4822 — *Application of AEP Texas Central Company, AEP Texas North Company, and AEP Utilities, Inc. for Approval of Merger*. As of January 2017, the merged company is doing business as AEP Texas Inc.

**JOINT APPLICATION OF LCRA TRANSMISSION SERVICES CORPORATION AND AEP TEXAS INC  
TO AMEND THEIR CERTIFICATES OF CONVENIENCE AND NECESSITY FOR THE BAKERSFIELD  
TO SOLSTICE 345-KV TRANSMISSION LINE PROJECT IN PECOS COUNTY, TEXAS**

---

**3. Person to Contact:**

**For joint applications, provide all information for each applicant.**

**Contact for LCRA TSC:**

Title/Position: Sonya Strambler  
Regulatory Case Manager  
Phone Number: (512) 578-1856  
Mailing Address: P.O. Box 220  
Mail Stop DSC D140  
Austin, TX 78767-0220  
Email Address: [sonya.strambler@lcra.org](mailto:sonya.strambler@lcra.org)

**Contact for AEP Texas:**

Title/Position: Randal E. Roper, PE  
Regulatory Case Manager  
Phone Number: (512) 481-4572  
Mailing Address: 400 W. 15<sup>th</sup> Street, Suite 1520  
Austin, Texas 78701  
Email Address: [reroper@aep.com](mailto:reroper@aep.com)

**Legal Counsel - LCRA TSC:**

Phone Number: Kirk Rasmussen  
(512) 615-1203  
Mailing Address: Enoch Keever PLLC  
5918 W. Courtyard Dr., Suite 500  
Austin, TX 78730  
Email Address: [krasmussen@enochkeever.com](mailto:krasmussen@enochkeever.com)

**Legal Counsel - AEP Texas:**

Phone Number: Jerry Huerta  
(512) 481-3323  
Mailing Address: 400 W. 15<sup>th</sup> Street, Suite 1520  
Austin, Texas 78701  
Email Address: [jnhuerta@aep.com](mailto:jnhuerta@aep.com)

Kerry McGrath  
(512) 744-9300  
Duggins Wren Mann & Romero, LLP  
600 Congress Avenue, 19<sup>th</sup> Floor  
Austin, Texas 78701  
[kmcgrath@dwmrlaw.com](mailto:kmcgrath@dwmrlaw.com)

**4. Project Description:**

**Name or Designation of Project**

Bakersfield to Solstice 345-kV Transmission Line Project in Pecos County, Texas  
(Project)

**JOINT APPLICATION OF LCRA TRANSMISSION SERVICES CORPORATION AND AEP TEXAS INC  
TO AMEND THEIR CERTIFICATES OF CONVENIENCE AND NECESSITY FOR THE BAKERSFIELD  
TO SOLSTICE 345-KV TRANSMISSION LINE PROJECT IN PECOS COUNTY, TEXAS**

---

**Provide a general description of the project, including the design voltage rating (kV), the operating voltage (kV), the CREZ Zone(s) (if any) where the project is located (all or in part), any substations and/or substation reactive compensation constructed as part of the project, and any series elements such as sectionalizing switching devices, series line compensation, etc. For HVDC transmission lines, the converter stations should be considered to be project components and should be addressed in the project description.**

The Proposed Transmission Line Project is located within Pecos County, Texas. The LCRA TSC Bakersfield Station is located approximately six miles north of Interstate Highway 10 (IH-10) and one mile west of Farm-to-Market Road 1901 (FM 1901). The AEP Texas Solstice Switch Station is located along IH-10 approximately 29 miles west of the City of Fort Stockton and near Hovey Road.

The Project will be designed, constructed, and operated as a double-circuit 345-kV transmission line connecting the Bakersfield and Solstice stations.

A portion of the Project is located within the McCamey CREZ Zone. HVDC facilities are not included as part of the project scope.

**If the project will be owned by more than one party, briefly explain the ownership arrangements between the parties and provide a description of the portion(s) that will be owned by each party. Provide a description of the responsibilities of each party for implementing the project (design, Right-Of-Way acquisition, material procurement, construction, etc.).**

LCRA TSC and AEP Texas will each own 50 percent of the Project. LCRA TSC will construct, own, operate, and maintain the eastern half of the transmission line connecting to LCRA TSC's Bakersfield Station (including all necessary construction within the Bakersfield Station) and AEP Texas will construct, own, operate, and maintain the western half of the transmission line connecting to AEP Texas' Solstice Switch Station (including all necessary construction to expand the Solstice Switch Station to terminate the Project). The AEP Texas Solstice Switch Station is currently a 138-kV station and will be expanded for a 345-kV station yard in a ring bus configuration. The new 345-kV station will be interconnected to the 138-kV station through two 600 MVA 345/138-kV autotransformers and a 50 Mvar reactor in conjunction with the Project will be added in the expanded station.

The dividing point of the Project will be determined following the Public Utility Commission of Texas' (PUC or Commission) approval of the final transmission line route. The structure closest to the middle of the approved route will be a deadend structure owned by AEP Texas. LCRA TSC's ownership will extend from the east to the point at which its conductors connect to AEP Texas' deadend structure. LCRA TSC will own, operate, and maintain all transmission line facilities, including conductors, wires, structures, hardware, and easements of the eastern half of the transmission line connecting to the Bakersfield Station and AEP Texas will own, operate, and maintain all transmission line facilities, including conductors, wires, structures, hardware, and easements of the western half of the transmission line connecting to the Solstice Switch

**JOINT APPLICATION OF LCRA TRANSMISSION SERVICES CORPORATION AND AEP TEXAS INC  
TO AMEND THEIR CERTIFICATES OF CONVENIENCE AND NECESSITY FOR THE BAKERSFIELD  
TO SOLSTICE 345-KV TRANSMISSION LINE PROJECT IN PECOS COUNTY, TEXAS**

---

Station. Each utility will be responsible for their respective portions of the Project, including design, right-of-way (ROW) acquisition, material procurement, construction, etc.

**If applicable, identify and explain any deviation in transmission project components from the original transmission specifications as previously approved by the Commission or recommended by a PURA §39.151 organization.**

In June 2017, the Board of Directors of the Electric Reliability Council of Texas (ERCOT) (a Public Utility Regulatory Act (PURA) § 39.151 organization) endorsed construction of the Project as a double-circuit capable 345-kV transmission line with an initial single circuit installed from Bakersfield to Solstice. In June 2018, in response to accelerating and increasing demand growth in the region, the ERCOT Board of Directors endorsed expanding the Project to include installation of the second circuit at the time of construction and determined that the Project was critical to the reliability of the ERCOT system. This Application reflects the changes to the specifications for the Project approved by the ERCOT Board of Directors in June 2018. The ERCOT recommendations are included as part of Attachment 2 to the Application.

**5. Conductor and Structures**

<b>Conductor Size and Type:</b>	1926.9 kmil ACSS/Cumberland (LCRA TSC) and 1590 ACSS (AEP Texas)
<b>Number of conductors per phase:</b>	Two (2) conductors per phase
<b>Continuous Summer Static Current Rating (A):</b>	Minimum 4,288 A
<b>Continuous Summer Static Line Capacity at Operating Voltage (MVA):</b>	2,564 MVA at 345-kV
<b>Continuous Summer Static Line Capacity at Design Voltage (MVA):</b>	2,564 MVA at 345-kV
<b>Type and Composition of Structures:</b>	Double-circuit steel lattice towers
<b>Height of Typical Structures:</b>	110 to 185 feet above the ground

**Explain why these structures were selected; include such factors as landowner preference, engineering considerations, and costs comparisons to alternate structures that were considered. Provide dimensional drawings of the typical structures to be used in the project.**

LCRA TSC and AEP Texas selected 345-kV lattice towers as the proposed structure type for the Project based primarily on cost,<sup>2</sup> efficiency,<sup>3</sup> and the other factors discussed in the Direct Testimony and Exhibit of Mr. Curtis Symank that are being filed concurrent with the Application. LCRA TSC and AEP Texas considered spun concrete poles, tower poles, tubular steel poles, and lattice towers as possible structures for the Project. Please refer to Figures 1-3 through 1-5 in the *Bakersfield to Solstice 345-kV Transmission Line Project Environmental Assessment and Alternative Route Analysis, Pecos County (EA)*, included as Attachment 1 to the Application, for dimensional drawings of the typical structures proposed to be used by LCRA TSC and AEP Texas for the Project.

**For joint applications, provide and separately identify the above-required information regarding structures for the portion(s) of the project owned by each applicant.**

AEP Texas and LCRA TSC will each use the same type of structures, discussed above, for their portion of the Project.

**6. Right-of-way:  
Miles of Right-of-Way:**

Approximately 68 to 92 total miles of Right-of-Way.

**Miles of Circuit:**

The Project is double-circuit, therefore, the project will result in approximately 130 to 190 miles of circuit.

**Width of Right-of-Way:**

Typical ROW for the Project will be 150 feet in width.

---

<sup>2</sup> Structure costs considered included the total installed cost of each structure including purchase, delivery, installation (including foundations), and the installed cost of hardware.

<sup>3</sup> For example, the weight of the structure and of structural steel.

**Percent of Right-of-Way Acquired:**

Zero.

**For joint applications, provide and separately identify the above-required information for each route for the portion(s) of the project owned by each applicant.**

During or after the hearing on the merits, Applicants will provide specific details about the estimated structure location of ownership transition for the routes under primary consideration at that juncture of the application process.

**Provide a brief description of the area traversed by the transmission line. Include a description of the general land uses in the area and the type of terrain crossed by the line.**

The Project will connect the existing LCRA TSC Bakersfield Station to the existing AEP Texas Solstice Switch Station. The Project area is located within Pecos County, Texas and includes the City of Fort Stockton.

The Project area is primarily rural with a variety of scattered land uses including commercial and residential development, transportation facilities, parks and recreation areas, rural agricultural areas, oil and gas developments, and wind energy production.

The Project area is situated within the southern portion of the High Plains, the northwest portion of the Edwards Plateau, and the southeast portion of the Basin and Range physiographic region of Texas. The southern High Plains region is described as nearly flat with playa lakes and local dune fields with elevations ranging from 2,200 feet to 3,800 feet above mean sea level (amsl). The Edwards Plateau region is described as a flat upper surface with box canyons with elevations ranging from 450 feet to 3,000 feet amsl. The Basin and Range region is characterized by north and south facing mountains and basins with elevations ranging from 1,700 feet to 8,750 feet amsl. Elevations in the study area range between approximately 2,300 feet amsl near the Pecos River in the northeast portions of the study area to approximately 3,600 feet on the hilltops and mesas in the southern portions of the study area.

Specific discussion regarding natural, human, and cultural resources in the Project area is set forth in the EA, Section 2.0.



**JOINT APPLICATION OF LCRA TRANSMISSION SERVICES CORPORATION AND AEP TEXAS INC  
TO AMEND THEIR CERTIFICATES OF CONVENIENCE AND NECESSITY FOR THE BAKERSFIELD  
TO SOLSTICE 345-KV TRANSMISSION LINE PROJECT IN PECOS COUNTY, TEXAS**

---

**7. Substations or Switching Stations:**

**List the name of all existing HVDC converter stations, substations or switching stations that will be associated with the new transmission line. Provide documentation showing that the owner(s) of the existing HVDC converter stations, substations and/or switching stations have agreed to the installation of the required project facilities.**

**List the name of all new HVDC converter stations, substations or switching stations that will be associated with the new transmission line. Provide documentation showing that the owner(s) of the new HVDC converter stations, substations and/or switching stations have agreed to the installation of the required project facilities.**

There are no existing or new HVDC converter stations associated with the Project. The eastern portion of the transmission line Project will terminate at LCRA TSC’s existing 345-kV Bakersfield Station. The western portion of the transmission line Project will terminate at AEP Texas’ existing Solstice Switch Station. The AEP Texas Solstice Switch Station is currently a 138-kV station and will be expanded to a 345-kV station yard adjacent to the 138-kV station.

**8. Estimated Schedule:**

<b><u>Estimated Dates of:</u></b>	<b><u>Start</u></b>	<b><u>Completion</u></b>
Right-of-way and Land Acquisition	May 2019 (LCRA TSC) May 2019 (AEP Texas)	October 2019 (LCRA TSC) October 2019 (AEP Texas)
Engineering and Design	June 2019 (LCRA TSC) May 2019 (AEP Texas)	November 2019 (LCRA TSC) December 2019 (AEP Texas)
Material and Equipment Procurement	December 2018 (LCRA TSC) June 2019 (AEP Texas)	February 2020 (LCRA TSC) February 2020 (AEP Texas)
Construction of Facilities	December 2019 (LCRA TSC) January 2020 (AEP Texas)	December 2020 (LCRA TSC) December 2020 (AEP Texas)
Energize Facilities	-	December 2020 (LCRA TSC) December 2020 (AEP Texas)

**9. Counties:**

**For each route, list all counties in which the route is to be constructed.**

All routes and route segments filed in this application are located in Pecos County, Texas.

Please refer to Figures 3-13, 3-14 (Appendix D), and 4-1 (Appendix E) in the EA for the location of alternative route segments.

**10. Municipalities:**

**For each route, list all municipalities in which the route is to be constructed.**

None of the alternative routes in this application will be constructed within the incorporated limits or ETJ of any municipality.

**For each applicant, attach a copy of the franchise, permit or other evidence of the city's consent held by the utility, if necessary or applicable. If franchise, permit, or other evidence of the city's consent has been previously filed, provide only the docket number of the application in which the consent was filed. Each applicant should provide this information only for the portion(s) of the project which will be owned by the applicant.**

Not applicable.

**11. Affected Utilities:**

**Identify any other electric utility served by or connected to facilities in this application.**

Other utilities connected at LCRA TSC's Bakersfield Station include Electric Transmission Texas (ETT), South Texas Electric Cooperative (STEC), and the City of Garland.

No other utilities connected at AEP Texas' Solstice Switch Station at the time of this application.

Oncor Electric Delivery Company and AEP Texas are simultaneously filing a CCN application for the Sand Lake to Solstice 345-kV transmission line (PUC Docket No. 48785), which will connect to the Solstice Switch Station.

**Describe how any other electric utility will be affected and the extent of the other utilities' involvement in the construction of this project. Include any other electric utilities whose existing facilities will be utilized for the project (vacant circuit positions, ROW, substation sites and/or equipment, etc.) and provide documentation showing that the owner(s) of the existing facilities have agreed to the installation of the required project facilities.**

No other electric utility will be involved in the construction of the Project. No other utilities' existing facilities will be utilized for the Project.

**JOINT APPLICATION OF LCRA TRANSMISSION SERVICES CORPORATION AND AEP TEXAS INC  
TO AMEND THEIR CERTIFICATES OF CONVENIENCE AND NECESSITY FOR THE PROPOSED  
BAKERSFIELD TO SOLSTICE 345-KV TRANSMISSION LINE PROJECT IN PECOS COUNTY, TEXAS**

**12. Financing:**

**Describe the method of financing this project. For each applicant that is to be reimbursed for all or a portion of this project, identify the source and amount of the reimbursement (actual amount if known, estimated amount otherwise) and the portion(s) of the project for which the reimbursement will be made.**

LCRA TSC will finance its portion of the Project similar to that which has been used for projects previously constructed by LCRA TSC. Financing may include a combination of tax-exempt commercial paper, tax-exempt private revolving note, or taxable commercial paper, and, subsequent to project completion, fixed-rate debt. Interest on the debt may be capitalized until the Project is in service, at which point it is intended that both the principal and interest will be serviced with Transmission Cost of Service revenues.

AEP Texas will finance its portion of the Project similar to that which has been used for projects previously constructed by AEP Texas. Financing will include a combination of short-term borrowings and owner equity.

**13. Estimated Costs: Provide cost estimates for each route of the proposed project using the following table. Provide a breakdown of “Other” costs by major cost category and amount. Provide the information for each route in an attachment to this application.**

	<u>Transmission Facilities *</u>	<u>Substation Facilities *</u>
Right-of-way and Land Acquisition	-	-
Engineering and Design (Utility)	-	-
Engineering and Design (Contract)	-	-
Procurement of Material and Equipment (including stores)	-	-
Construction of Facilities (Utility)	-	-
Construction of Facilities (Contract)	-	-
Other (all costs not included in the above categories)	-	-
<b>Estimated Total Cost</b>	See Attach. 3	See Attach. 3

\*Please refer to Attachment 3 to this Application for Transmission and Station Facilities estimated costs for each alternative route presented in this Application.

**For joint applications, provide and separately identify the above-required information for the portion(s) of the project owned by each applicant.**

The cost estimates presented in Attachment 3 represent a reasonable estimate of the costs for the transmission facilities portion of the Project. The per mile costs for constructing the transmission line portion of the Project (e.g., materials, labor, ROW) will be very similar for LCRA TSC and AEP Texas. In preparing the cost estimates for each route, AEP Texas and LCRA TSC did not attempt to separate costs by utility. AEP Texas and LCRA TSC will each be responsible for construction of 50 percent of the transmission line portion of the Project. The station costs for each utility are presented separately in Attachment 3.

**14. Need for the Proposed Project:**

**For a standard application, describe the need for the construction and state how the proposed project will address the need. Describe the existing transmission system and conditions addressed by this application. For projects that are planned to accommodate load growth, provide historical load data and load projections for at least five years. For projects to accommodate load growth or to address reliability issues, provide a description of the steady state load flow analysis that justifies the project. For interconnection projects, provide any documentation from a transmission service customer, generator, transmission service provider, or other entity to establish that the proposed facilities are needed. For projects related to a Competitive Renewable Energy Zone, the foregoing requirements are not necessary; the applicant need only provide a specific reference to the pertinent portion(s) of an appropriate commission order specifying that the facilities are needed. For all projects, provide any documentation of the review and recommendation of a PURA §39.151 organization.**

The Project and associated station work was reviewed by stakeholders and endorsed by the Electric Reliability Council of Texas (“ERCOT”) through the ERCOT Regional Planning Group (“RPG”) project review process, as part of the Far West Texas Project and the Far West Texas 2 Project. ERCOT performed power flow studies as part of the ERCOT RPG process and found voltage and thermal violations under the North American Electric Reliability Corporation (“NERC”) Standard TPL-001-4 reliability criteria. ERCOT recommended the Project as one of the components that would provide the most effective solution to meet reliability needs and provide infrastructure to accommodate future load growth. The Project has also received approval by both the ERCOT Technical Advisory Committee (“TAC”) and the ERCOT Board of Directors. See Far West Texas Project ERCOT Endorsement Letter dated June 2017 and Independent Review dated May 2017 included as Attachment 2a. Also see Far West Texas 2 Project ERCOT Endorsement Letter dated June 2018 and Independent Review dated May 2018 included as Attachment 2d.

The electric utilities principally serving load in West Texas—Oncor, AEP Texas, and Texas New Mexico Power—continue to experience load growth in their respective service areas due to oil and natural gas production, mid-stream processing, and associated economic expansion in the area referred to as the Delaware Basin. In order to meet this need, a new transmission line (Sand Lake to Solstice 345-kV Electric Transmission Line Project; PUC Doc. No. 48785) in Pecos, Reeves, and Ward Counties is being proposed by

**JOINT APPLICATION OF LCRA TRANSMISSION SERVICES CORPORATION AND AEP TEXAS INC  
TO AMEND THEIR CERTIFICATES OF CONVENIENCE AND NECESSITY FOR THE BAKERSFIELD  
TO SOLSTICE 345-KV TRANSMISSION LINE PROJECT IN PECOS COUNTY, TEXAS**

---

Oncor and AEP Texas to connect Oncor’s Sand Lake Switch, located in Ward County, to AEP Texas’ Solstice Switch, located in Pecos County. In addition to the Sand Lake to Solstice Project, LCRA TSC and AEP Texas are proposing to construct the transmission line included in this Application (Bakersfield to Solstice 345-kV Electric Transmission Line) to meet the needs of the region. See Figure 1 below for the locations of these stations.

Pecos, Reeves, and Ward Counties lie within the West Texas region of the Delaware Basin where deep underground shale deposits referred to as “plays” are providing opportunities for oil and natural gas exploration and production. Improvements in oil and natural gas exploration technologies have increased activity in the area and resulted in electric load growth at substations within the Delaware Basin. This growth has resulted in increased load served on Oncor’s existing Wink – Culberson Switch 138-kV Line and Yucca Drive Switch – Culberson Switch 138-kV Lines (referred to as “The Culberson Loop”). Additionally, this growth has resulted in increased load on AEP Texas’ 138 kV lines exiting Solstice Switch (referred to as “The Barilla Junction Area”). See Figure 1 below for the locations of these lines.

This rapid load growth threatens transmission reliability in the area. Oncor identified numerous contingencies that resulted in unacceptable voltage conditions along The Culberson Loop transmission lines. Studies showed that multiple NERC TPL-001-4 contingences would result in unsolved contingencies during load flow analysis. The unsolved contingencies show an inability of the power system to maintain acceptable voltages following a disturbance, resulting in potential voltage collapse along these lines. Such scenarios could cause all customers served from these lines to be dropped. Additionally, AEP Texas identified numerous contingencies that resulted in thermal violations along The Barilla Junction Area transmission lines. These violations are an indication that the current capacity of existing transmission lines in the area is insufficient and that loading can exceed their existing ratings.

Ultimately Oncor and AEP Texas determined that a strong source, which a new 345-kV injection provides, is required to support voltage conditions and line loading in the area, especially as load continues to grow. As a result, Oncor and AEP Texas proposed the Far West Texas Project to the ERCOT RPG, which included a new 345-kV transmission loop between Odessa EHV to Moss to Riverton to Sand Lake to Solstice to Bakersfield stations. See Attachment 2b for the Oncor and AEP Texas Far West Texas Project RPG Submittal report.

As part of the original Far West Texas Project, ERCOT saw similar concerns and confirmed the need for 345-kV facilities in the project study area. ERCOT recommended the establishment of a new 345-kV transmission line between the Riverton and Odessa EHV Switch stations, and a new 345-kV transmission line between the Solstice and Bakersfield stations. For details of ERCOT’s analysis and recommendations in the original Far West Texas Project, please see ERCOT’s June 2017 Endorsement Letter and Independent Review dated May 2017 included as Attachment 2a.

ERCOT also indicated the potential need for future improvements as load grows in the area, including future 345-kV circuits between Riverton and Sand Lake, as well as Sand Lake and Solstice. This 345-kV line segment from Riverton to Sand Lake to Solstice was part of the original Far West Texas Project proposal; however, ERCOT did not initially

**JOINT APPLICATION OF LCRA TRANSMISSION SERVICES CORPORATION AND AEP TEXAS INC  
TO AMEND THEIR CERTIFICATES OF CONVENIENCE AND NECESSITY FOR THE BAKERSFIELD  
TO SOLSTICE 345-KV TRANSMISSION LINE PROJECT IN PECOS COUNTY, TEXAS**

approve construction of all these segments as part of its independent review. ERCOT recommended that the need for these circuits be re-evaluated when confirmed load projections on The Culberson Loop reached 717 MW.

Table 1 below shows the sum of historical and projected summer peak loads (MW) for the substations on The Culberson Loop transmission lines. The loads from 2013 to 2017 are actual non-coincident summer peaks. The load for 2018 is the projected peak, expected to occur between the last date the forecast was updated and the end of the year, and only includes confirmed load increases for Oncor substations and customer requests that have signed agreements for service. The loads for 2019 to 2023 are projected non-coincident summer peaks and only include confirmed load increases for Oncor substations and customer requests that have signed agreements for service.

	Historical Load					Projected Load					
	2013	2014	2015	2016	2017	2018	2019	2020	2021	2022	2023
<b>Total (MW)</b>	<b>48.5</b>	<b>81.7</b>	<b>93.7</b>	<b>205.4</b>	<b>246.4</b>	<b>771</b>	<b>902</b>	<b>1318</b>	<b>1475</b>	<b>1549</b>	<b>1597</b>

**Table 1 - Historical and Projected Load on the Wink – Culberson and Yucca Drive – Culberson 138-kV Transmission Lines**

Table 2 below was provided by AEP Texas and shows historical and projected summer peak loads (MW) in The Barilla Junction Area for the same period. The jump in the projected load in 2019 is the result of new oil field activity underway and load request that was not projected when the Far West Texas Project submission was made.

	Historical Load					Projected Load					
	2013	2014	2015	2016	2017	2018	2019	2020	2021	2022	2023
<b>Total (MW)</b>	<b>278.4</b>	<b>271.8</b>	<b>322.8</b>	<b>312.5</b>	<b>396.6</b>	<b>458</b>	<b>672</b>	<b>886</b>	<b>1010</b>	<b>1061</b>	<b>1075</b>

**Table 2 - Historical and Projected Load The Barilla Junction Area**

With future load additions, Oncor’s steady state contingency analysis shows that loss of the future radial Odessa EHV – Riverton 345 -kV Line, a NERC category P1.2 contingency, results in multiple voltage violations along The Culberson Loop as load grows along these lines in future years. The result indicates that a single-line outage of the radial 345-kV transmission line will result in a service interruption to all customers served within The Culberson Loop. This analysis also indicates that taking a clearance on the radial 345-kV line will be problematic.

As a result, Oncor, in coordination with AEP Texas and LCRA TSC, proposed the Far West Texas Project 2 to the ERCOT RPG, which included the Riverton to Sand Lake and Sand Lake to Solstice 345-kV Lines and the initial installation of the second circuit on the Bakersfield to Solstice 345-kV Line. These projects would provide bidirectional service for the 345-kV source into The Culberson Loop, ultimately addressing the criteria violations mentioned previously. See Attachment 2c for the Oncor Far West Texas Project 2 RPG Submittal report. ERCOT’s independent review confirmed the reliability need to expand the 345-kV transmission system in the region. Constructing the Bakersfield to Solstice and

**JOINT APPLICATION OF LCRA TRANSMISSION SERVICES CORPORATION AND AEP TEXAS INC  
TO AMEND THEIR CERTIFICATES OF CONVENIENCE AND NECESSITY FOR THE BAKERSFIELD  
TO SOLSTICE 345-KV TRANSMISSION LINE PROJECT IN PECOS COUNTY, TEXAS**

---

Sand Lake to Solstice 345-kV lines will be components to allow bidirectional flow in the area on the new 345-kV lines, ultimately allowing voltage support from the stronger 345-kV injection to address reliability concerns in the region such as the single-line outage of a radial 345-kV line. In addition, this would improve: operational flexibility during emergency conditions, obtaining clearances for maintenance of equipment, and connecting new loads to the system.

On June 12, 2018, the ERCOT Board of Directors endorsed the recommendation of the Independent Review recommending transmission improvements, including the components of the Project that are the subject of this application. See ERCOT Endorsement Letter dated June 2018 and Independent Review dated May 2018 included as Attachment 2d.

Critical Designation

In May 2018, Oncor, AEP Service Company (AEPSC) on behalf of AEP Texas, and LCRA TSC submitted a formal request to ERCOT to grant critical designation status for the Riverton – Sand Lake, the Sand Lake – Solstice, and the Bakersfield – Solstice 345-kV Double-Circuit Lines, pursuant to 16 Texas Administrative Code § 25.101 (b)(3)(D). See letter dated May 14, 2018 included as Attachment 2e.

In the request, the companies described the acceleration of load growth being experienced in the region and the criticality of 345-kV service to the reliability of the area. Load growth in the area has surpassed ERCOT’s expected load serving capability for existing planned projects in the area.

On June 12, 2018, the ERCOT Board of Directors designated the Riverton - Sand Lake 345 kV line, the Sand Lake - Solstice 345 kV and the Bakersfield – Solstice Double-Circuit 345 kV lines critical to the reliability of the ERCOT System. See ERCOT Board of Directors’ resolution included as Attachment 2f.

ERCOT’s endorsement and critical designation confirms the multiple operational and reliability needs for the Project, and highlights the necessity for the 345-kV facilities to be placed in-service as soon as possible.

Supplemental Information

On October 15, 2018, ERCOT identified the completion of the 345-kV components of the Far West Texas Project and the Far West Texas Project 2 that complete a transmission path from Bakersfield to Solstice to Sand Lake to Riverton to Odessa EHV as the exit strategy for a Generic Transmission Constraint established for the McCamey area. See Attachment 2g.

**15. Alternatives to Project:**

**For a standard application, describe alternatives to the construction of this project (not routing options). Include an analysis of distribution alternatives, upgrading voltage or bundling of conductors of existing facilities, adding transformers, and for utilities that have not unbundled, distributed generation as alternatives to the project. Explain how the project overcomes the insufficiencies of the other options that were considered.**

Alternatives to the Project were studied as part of the ERCOT RPG process in both the Far West Texas Project and the Far West Texas Project 2.

Far West Texas Project

In ERCOT's independent review of the Far West Texas Project, ERCOT reviewed 40 different alternatives. The alternatives included numerous variations of different 138-kV and 345-kV transmission lines and reactive compensation devices. Additionally, ERCOT examined various termination points for new transmission lines and new reactive compensation. Ultimately ERCOT narrowed down the alternatives to four main options for detailed study.

Option 1:

- Install a new 200 MVAR Dynamic Synchronous Condenser at Mentone 138-kV Substation.
- Install a new 200 MVAR Dynamic Synchronous Condenser at Culberson 138-kV Substation.
- Construct a new approximately 85-mile 345-kV line operating at 138-kV on double-circuit structures with one circuit in place, between Moss and Riverton Switch stations.
- Add a second circuit to the existing 16-mile Moss Switch station – Odessa EHV 345-kV double-circuit structures. Connect the new circuit from Riverton Switch station and terminate at Odessa EHV to create the new Odessa EHV - Riverton 345-kV line operating at 138-kV.
- Build a new McCamey – Fort Stockton 345-kV double circuit line operating at 138-kV (requiring approximately 47-miles of new right of way).
- Build a new Pig Creek – Fort Stockton 345-kV single circuit line operating at 138-kV (requiring approximately 39-miles of new right of way).
- Install a new 50 MVAR capacitor bank each at Mentone and Salt Creek 138-kV Substations.
- Install a new 18 MVAR capacitor bank each at Orla, Elmar, Loving and Alamito Creek 138-kV Substations.
- Install a new 3.6 MVAR capacitor bank at Espy Wells 69 kV Substation.
- Install a new 10.8 MVAR capacitor bank at Shafter Goldmine 69 kV Substation.
- Install a new 7.2 MVAR capacitor bank at Sanderson TNP 69 kV Substation.

The total cost estimate for Option 1 is approximately \$464 Million.



**JOINT APPLICATION OF LCRA TRANSMISSION SERVICES CORPORATION AND AEP TEXAS INC  
TO AMEND THEIR CERTIFICATES OF CONVENIENCE AND NECESSITY FOR THE PROPOSED  
BAKERSFIELD TO SOLSTICE 345-KV TRANSMISSION LINE PROJECT IN PECOS COUNTY, TEXAS**

---

Option 2:

- Expand the Riverton Switch station to install a 345-kV ring-bus arrangement with two 600 MVA, 345/138-kV autotransformers.
- Construct a new approximately 85-mile 345-kV line on double-circuit structures with one circuit in place, between Moss and Riverton Switch stations. Add a second circuit to the existing 16-mile Moss Switch – Odessa EHV 345-kV double-circuit structures. Install 345-kV circuit breaker(s) at Odessa EHV. Connect the new circuit from Riverton Switch station and terminate at Odessa EHV to create the new Odessa EHV – Riverton 345-kV Line.
- Expand the Solstice Switch station to install a 345-kV ring-bus arrangement with two 600 MVA, 345/138-kV autotransformers.
- Construct a new approximately 68-mile 345-kV line from Solstice Switch station to Bakersfield station on double-circuit structures with one circuit in place.

The total cost estimate for Option 2 is approximately \$336 Million.

Option 3:

- Expand the Riverton Switch station to install a 345-kV ring-bus arrangement with two 600 MVA, 345/138-kV autotransformers.
- Construct a new approximately 85-mile 345-kV line on double-circuit structures with one circuit in place, between Moss and Riverton Switch stations. Add a second circuit to the existing 16-mile Moss Switch – Odessa EHV 345-kV double-circuit structures. Install 345-kV circuit breaker(s) at Odessa EHV. Connect the new circuit from Riverton Switch station and terminate at Odessa EHV to create the new Odessa EHV – Riverton 345-kV Line.
- Expand the Riverton Switch station to install a 345-kV ring-bus arrangement with two 600 MVA, 345/138-kV autotransformers.
- Expand the Sand Lake Switch station to install a 345-kV ring-bus arrangement with one 600 MVA, 345/138-kV autotransformer.
- Expand the Solstice Switch station to install a 345-kV ring-bus arrangement with two 600 MVA, 345/138-kV autotransformers.
- Construct a new approximately 41-mile 345-kV line on double-circuit structures with one circuit in place, Sand Lake – Solstice 345-kV single circuit line (the proposed transmission line).
- Add a second circuit to the Riverton – Mentone – Sand Lake 345-kV to create a Riverton – Sand Lake 345-kV line on the existing Riverton – Mentone – Sand Lake 345-kV line operating at 138-kV.
- Construct a new approximately 68-mile 345-kV line from Solstice Switch to Bakersfield on double-circuit structures with one circuit in place.

The total cost estimate for Option 3 is approximately \$446 Million.

Option 4:

- Option 4 is same as Option 3 with an additional new 200 MVAR Synchronous Condenser at Culberson 138-kV Substation.

The total cost estimate for Option 4 is approximately \$501 Million.

**JOINT APPLICATION OF LCRA TRANSMISSION SERVICES CORPORATION AND AEP TEXAS INC  
TO AMEND THEIR CERTIFICATES OF CONVENIENCE AND NECESSITY FOR THE BAKERSFIELD  
TO SOLSTICE 345-KV TRANSMISSION LINE PROJECT IN PECOS COUNTY, TEXAS**

---

ERCOT's analysis indicated that all of the four options addressed the reliability needs in The Culberson Loop with the projected load conditions at the time of the submittal in 2016. Oncor provided additional information to ERCOT for additional loads not yet under contract as of the study date, but which were known to want service in the near future. ERCOT used this information for their sensitivity study in which they found that all NERC criteria violations could not be addressed by Options 1 and 2. Options 3 and 4 showed no violations even under the sensitivity study scenario.

ERCOT endorsed Option 2, which included a variation of the Project (a 345-kV transmission line between Bakersfield and Solstice as double-circuit capable with a single circuit installed initially), as the best solution to address the reliability needs of the region. Ultimately elements of Option 3 and 4, were later endorsed by ERCOT through its independent review of the Far West Texas Project 2.

Far West Texas Project 2

In ERCOT's independent review of the Far West Texas Project 2, ERCOT revisited the alternatives and approved project elements from the initial Far West Texas Project based on new load additions in the region. ERCOT narrowed down a shortlist of "universal" transmission upgrades as part of its alternatives development in order to align with the expansion options from its original analysis of the Far West Texas Project.

The "universal" options included:

- Construct a new approximately 40-mile 345-kV line on double-circuit structures with two circuits in place from Sand Lake 345-kV Switch to Solstice 345-kV Switch.
- Add two new 600 MVA, 345/138-kV autotransformers at Sand Lake 345-kV Switch station.
- Install a new 345-kV circuit on the planned Riverton – Sand Lake double circuit structures.
- Install the second 345-kV circuit on the Odessa EHV – Riverton 345-kV line double circuit structures between Moss and Riverton (creating a Moss – Riverton 345-kV circuit).
- Construct a new Quarry Field 138-kV Switch station in the Wink – Riverton double-circuit 138-kV line.
- Construct a new approximately 20-mile Kyle Ranch – Riverton 138-kV line on double-circuit structures with one circuit in place from Kyle Ranch 138-kV Substation to Riverton 138-kV Switch station.
- Construct a new approximately 20-mile Owl Hills – Tunstill – Riverton 138-kV line on double circuit structures with one circuit in place from Owl Hills 138-kV Substation to Riverton 138-kV Switch station.
- Install the second 345-kV circuit on the planned Solstice Switch – Bakersfield Switch double circuit structures.

**JOINT APPLICATION OF LCRA TRANSMISSION SERVICES CORPORATION AND AEP TEXAS INC  
TO AMEND THEIR CERTIFICATES OF CONVENIENCE AND NECESSITY FOR THE PROPOSED  
BAKERSFIELD TO SOLSTICE 345-KV TRANSMISSION LINE PROJECT IN PECOS COUNTY, TEXAS**

---

Using these “universal” upgrades in each of the final options, ERCOT further studied three final options.

Option 1:

- Install two 250 MVAR Static Synchronous Compensators at Horseshoe Springs 138-kV Switch station.

The total cost estimate for Option 1 is approximately \$300.0 Million.

Option 2:

- Install one 250 MVAR Static Synchronous Compensator (“STATCOM”) at Horseshoe Springs 138-kV Switch station.
- Install capacitor banks with a total capacity of 150 MVAR at Horseshoe Springs 138-kV Switch station.
- Install capacitor banks with a total capacity of 150 MVAR at Quarry Field 138-kV Switch station.

The total cost estimate for Option 2 is approximately \$292.5 Million.

Option 3:

- Install one 250 MVAR STATCOM at Horseshoe Springs 138-kV Switch station.
- Install one 250 MVAR STATCOM at Quarry Field 138-kV Switch station.
- Install capacitor banks with a total capacity of 150 MVAR at Horseshoe Springs 138-kV Switch station.
- Install capacitor banks with a total capacity of 150 MVAR at Quarry Field 138-kV Switch station.

The total cost estimate for Option 3 is approximately \$446.0 Million.

ERCOT’s analysis indicated that all three options addressed the reliability needs in The Culberson Loop with the projected future load conditions. ERCOT ultimately recommended Option 3 as the option with the best load serving capability to accommodate both near-term and potential future load needs in the area.

The Bakersfield Station was chosen as an end point for the Project because Bakersfield is the strongest and main 345-kV source in the area through existing 345-kV transmission line connections to the Odessa EHV substation the north and Big Hill substation to the east. Weaker sources would not provide the appropriate voltage support to the underlying 138-kV system in the area where the reliability violations have been identified. There are no other feasible 345-kV facilities in the area, so Bakersfield is the best location to interconnect to the 345-kV transmission system for a strong voltage source. The existing 345-kV line from Bakersfield to the Odessa EHV Switch, when considered with the improvements contained in the Project, creates a 345-kV transmission loop to provide support to the load growth in west Pecos County and along the Culberson Loop. Creating the bi-directional looped service capability for the 345-kV system in the area is needed to meet the reliability and operational flexibility required for existing and future customers.

**JOINT APPLICATION OF LCRA TRANSMISSION SERVICES CORPORATION AND AEP TEXAS INC  
TO AMEND THEIR CERTIFICATES OF CONVENIENCE AND NECESSITY FOR THE BAKERSFIELD  
TO SOLSTICE 345-KV TRANSMISSION LINE PROJECT IN PECOS COUNTY, TEXAS**

---

The Solstice Switch Station was chosen as an end point for the Project because of its ideal location for electrical connection. At the Solstice and the adjacent Barilla Junction stations, there are terminations of eight different transmission circuits with connections to major switch stations for the region, including Pig Creek/Yucca Drive, Fort Stockton Switch, and Fort Stockton Plant. All lines and customers served from these lines would benefit from the new 345-kV source. Since Solstice Switch is a major 138-kV transmission hub within Pecos County, all of these transmission lines and customers served from these lines would benefit from the future 345-kV injection. Solstice is also the end point for the planned Sand Lake – Solstice 345-kV Line. A different endpoint from Solstice would not take advantage of the already planned project to bring 345-kV facilities to the area.

Distribution alternatives are not practical alternatives since they would not improve the reliability and operational capability of the transmission system in the area.

Upgrading voltage of existing facilities would not be practical since a new independent 345-kV source and pathway in the area is needed, and all existing facilities in the area are either constructed and operated at 138-kV or being upgraded for the capability. The 138-kV facilities in the area currently serve customers directly, so upgrading voltage on those lines would require all customers and existing stations to be rebuilt in order to be served from 345-kV.

Increasing the capacity of the radial 345-kV facilities already certificated and under construction by Oncor or bundling of conductors on existing 138-kV facilities would not address the reliability and operational issues under the contingency of concern because bundling conductors does not provide bi-directional looped service capability which is needed to address the reliability issues and provide operational flexibility for existing and future customers.

These reliability and operational issues are discussed in further detail in Brent Kawakami's direct testimony.

**JOINT APPLICATION OF LCRA TRANSMISSION SERVICES CORPORATION AND AEP TEXAS INC  
TO AMEND THEIR CERTIFICATES OF CONVENIENCE AND NECESSITY FOR THE BAKERSFIELD  
TO SOLSTICE 345-KV TRANSMISSION LINE PROJECT IN PECOS COUNTY, TEXAS**

**16. Schematic or Diagram:**

For a standard application, provide a schematic or diagram of the applicant's transmission system in the proximate area of the project. Show the location and voltage of existing transmission lines and substations, and the location of the construction. Locate any taps, ties, meter points, or other facilities involving other utilities on the system schematic.

Figure 1 below reflects a geographical representation of the new and existing area transmission system. Figure 2 below is an electrical schematic illustrating the Project.

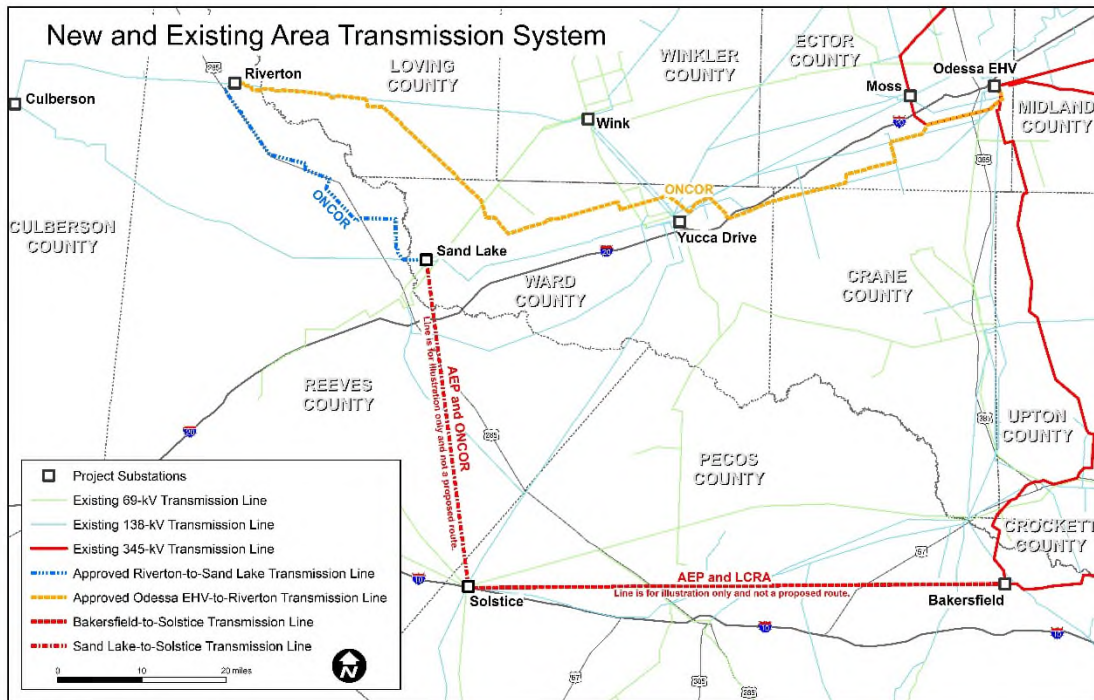

**Figure 1  
New and Existing Area Transmission System**

**JOINT APPLICATION OF LCRA TRANSMISSION SERVICES CORPORATION AND AEP TEXAS INC  
TO AMEND THEIR CERTIFICATES OF CONVENIENCE AND NECESSITY FOR THE BAKERSFIELD  
TO SOLSTICE 345-KV TRANSMISSION LINE PROJECT IN PECOS COUNTY, TEXAS**

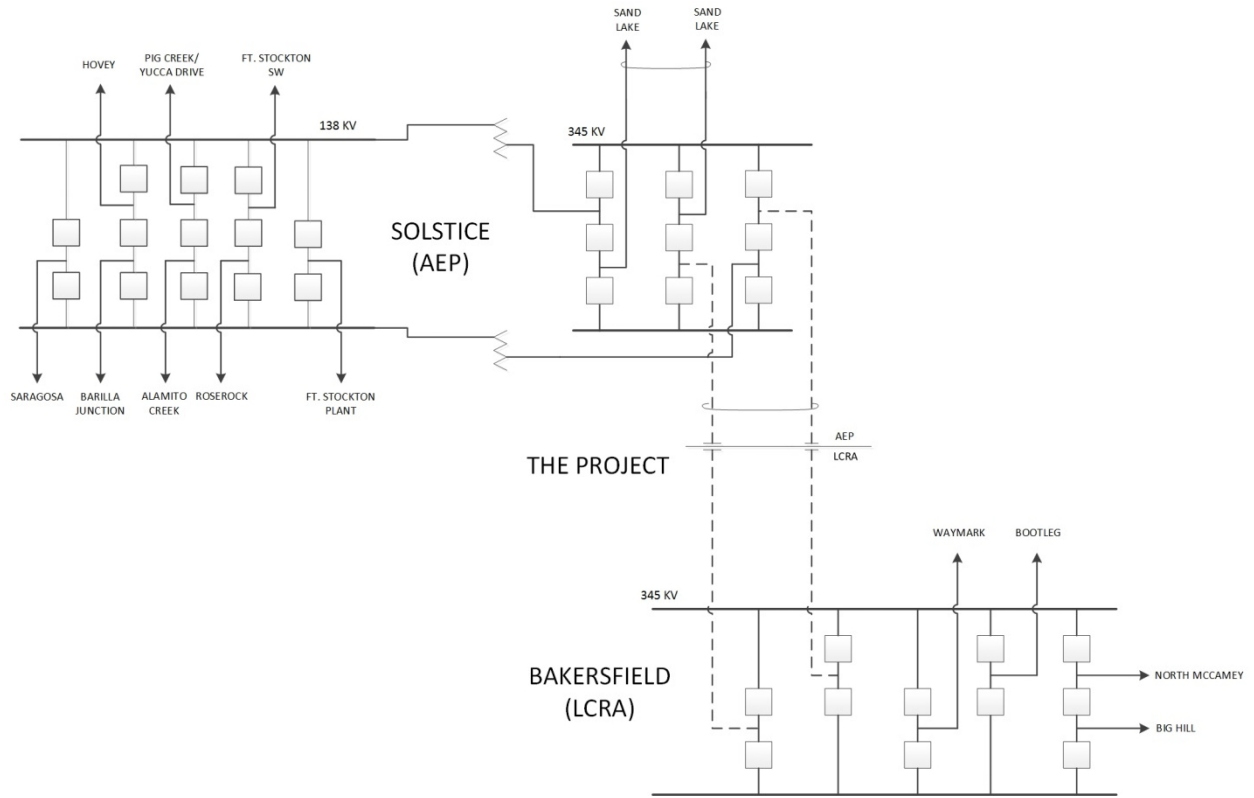

**Figure 2  
Schematic View of the The Project**

**17. Routing Study:**

**Provide a brief summary of the routing study that includes a description of the process of selecting the study area, identifying routing constraints, selecting potential line segments, and the selection of the routes. Provide a copy of the complete routing study conducted by the utility or consultant. State which route the applicant believes best addresses the requirements of PURA and P.U.C. Substantive Rules.**

LCRA TSC and AEP Texas retained POWER Engineers (POWER) to prepare the EA, included as Attachment 1 to the Application. The objective of the EA was to provide information in support of this Application and to identify and evaluate a number of geographically diverse routes that are in accordance with the requirements of PURA § 37.056 (c)(4)(A)-(D), the Commission’s Certificate of Convenience and Necessity (CCN) Application form, Commission Substantive Rule 25.101, and the preliminary order requirements commonly issued by the Commission for CCN projects. The EA presents the analysis that was conducted by POWER, including land use and environmental data and the effects that could result from the construction, operation, and maintenance of the

**JOINT APPLICATION OF LCRA TRANSMISSION SERVICES CORPORATION AND AEP TEXAS INC  
TO AMEND THEIR CERTIFICATES OF CONVENIENCE AND NECESSITY FOR THE BAKERSFIELD  
TO SOLSTICE 345-KV TRANSMISSION LINE PROJECT IN PECOS COUNTY, TEXAS**

---

Project. The EA may also be used in support for any local, state, or federal permitting activities that may be required for the Project.

To assist POWER in its evaluation, LCRA TSC and AEP Texas provided information regarding the Project endpoints, need for the Project, engineering and design requirements, construction practices, and ROW requirements for the Project.

**Selecting the Study Area**

POWER, with input from LCRA TSC and AEP Texas, delineated the study area that encompassed the Project endpoints with an area sufficient for identifying geographically diverse routes. The study area was defined by the existing Project endpoints, existing ROW (roadways, railroads, and transmission lines), and existing cultural and land use features (including the Pecos County line). The study area is approximately 65 miles long by 31 miles wide, and covers an area of approximately 1,908 square miles (1,221,120 acres). The study area is shown on Figure 2-1 of the EA.

**Routing Constraints**

Routing constraints were identified once the study area was defined based on the criteria established in PURA § 37.056(c)(4)(A)-(D), the Commission's CCN Application form, Commission Substantive Rule 25.101, and the preliminary order requirements commonly issued by the Commission for CCN projects. POWER gathered data related to land use, aesthetics, ecology, and cultural resources. Data was collected from a variety of resources including: input from federal, state and local agencies, available maps and recent aerial imagery, ground reconnaissance surveys and input from the public open house meeting. Following this process allowed for identification of environmental and land use features such as habitable structures, parks, agriculture activities (including pivot irrigation), oil and gas wells, wind turbines and solar farms, designated critical habitat, and known cultural resource sites within the study area.

**Selection of Preliminary Alternative Route Segments**

Preliminary alternative route segments were identified by evaluating the mapped routing constraints data within the study area; identifying potential routing opportunities by following existing corridors such as existing roads, transmission lines, railroads, and property lines; and coordinating with University Lands (which manages significant surface and mineral interests within the study area for the benefit of the Permanent University Fund). Field reconnaissance was conducted from public access points, roads and highways to verify the feasibility of route segments. Preliminary alternative route segments were delineated to avoid known environmental and land use constraints to the extent possible. The preliminary alternative route segments were then presented to the public at an open house meeting.

Based on feedback received during and following the open house meeting, further review and input from LCRA TSC and AEP Texas, POWER modified and added additional

alternative route segments. Ultimately, 25 primary alternative routes were identified for evaluation. Evaluation of each of the primary alternative routes was based on 46 land use and environmental criteria.

Specific discussion regarding selection of the study area, identification of constraints, the identification of preliminary alternative route segments, and the evaluation of primary alternative routes is set forth in Sections 2.0, 3.0 and 4.0 of the EA.

**Selection of the alternative route the applicant believes best addresses the requirements of PURA and P.U.C. Substantive Rules**

Upon evaluation of the primary alternative routes, LCRA TSC and AEP Texas selected Route 24 as the primary alternative route that the joint applicants believe best addresses the requirements of PURA and the Commission's Substantive Rules. Route 24 was identified based, in part, on the following considerations:

- Has the highest percentage paralleling and adjacent to existing corridors (transmission lines, public roads/highways and apparent property boundaries) for approximately 86 percent of its total estimated length (61.5 miles of 71.1 miles);
- Has a significant portion of length parallel and adjacent to an existing transmission line currently being rebuilt from 69-kV to 138-kV which will decrease the amount of new disturbance;
- Has the 4th shortest length (along with Route 4) of the 25 primary alternative routes included in the Application (approximately 71.1 miles) and is only 3.3 miles longer than the shortest route;
- Relatively low cost, as the 4th lowest cost of the 25 primary alternative routes included in the Application (approximately \$155,960,000);
- Has a relatively lower habitable structure count of 5 (habitable structures range from 0 to 14);
- Relatively low overall aesthetic impact;
- Crosses two recorded cultural resources sites and has two additional recorded resources sites located within 1,000 feet of the centerline;
- Has only 34 pipeline crossings (pipeline crossings range from 20 to 46).

In addition, the study area has significant continuing oil and gas facility growth, including pipeline construction. To the extent engineering obstacles are encountered after Commission approval that result from this continued growth, the route may need to be modified to the minimum extent necessary to avoid encountered obstacles. The Applicants will request that the Commission's Final Order provide the ability to address such facility growth consistent with good utility practice.



**18. Public Meeting or Public Open House:**

**Provide the date and location for each public meeting or public open house that was held in accordance with P.U.C. PROC. R. 22.52. Provide a summary of each public meeting or public open house including the approximate number of attendants, and a copy of any survey provided to attendants and a summary of the responses received. For each public meeting or public open house provide a description of the method of notice, a copy of any notices, and the number of notices that were mailed and/or published.**

LCRA TSC and AEP Texas hosted a public open house meeting for the Project on July 12, 2018, in Fort Stockton, Texas. The open house was held from 5:30 p.m. to 8:00 p.m. at the Pecos County Civic Center. Approximately 1,440 notices were mailed to owners of land within 500 feet of the centerline for each preliminary alternative route segment. Notices were also mailed to local officials, other interested parties, and the U.S. Department of Defense Siting Clearinghouse. This notice included a map of the study area depicting the preliminary alternative route segments and a frequently asked questions document. An example of the notice mailed to landowners and a copy of the attachments are located in Appendix B of the EA.

Public notice for the open house meeting was also published in *The Fort Stockton Pioneer*, a newspaper of general circulation within Pecos County, on July 5 and July 12, 2018, and announced the location, time and purpose of the meeting. An example of the published public notice is located in Appendix B of the EA.

The purpose of the meeting was to solicit comments and input from landowners, public officials, and other interested parties in regard to the purpose, need, and potential impacts and benefits of the Project and to gather a better understanding of community values and concerns. It also provided the opportunity to inform the public of the Commission certification process, routing procedures, schedule, and route approval process.

The meeting was organized as an informal come and go format with information stations that were occupied with representatives from LCRA TSC, AEP Texas, or POWER. The stations consisted of: text displays explaining various topics, topography, segment and notification maps, aerial photography, and a GIS computer station. Upon arrival, attendees were offered a preliminary alternative route segments map, questionnaire, and a frequently asked questions document. This meeting format is typically better for attendees as it allows them the opportunity to gather particular information that is most important to them and focus on topics they are most interested in. This format also allows for more individualized discussions from attendees who otherwise might be hesitant to participate in a formal presentation setting.

A total of 49 individuals attended the public open house meeting, with 16 questionnaires submitted at the meeting. An additional seven questionnaires were received after the open house for a total of 23 questionnaires submitted for the Project.

Additional information concerning the public involvement process and summarized questionnaire results is located in Section 3 of the EA. A representative copy of the questionnaire provided for the Project is included in Appendix B of the EA.

**19. Routing Maps:**

**Base maps should be a full scale (one inch = not more than one mile) highway map of the county or counties involved, or other maps of comparable scale denoting sufficient cultural and natural features to permit location of all routes in the field. Provide a map (or maps) showing the study area, routing constraints, and all routes or line segments that were considered prior to the selection of the routes. Identify the routes and any existing facilities to be interconnected or coordinated with the project. Identify any taps, ties, meter points, or other facilities involving other utilities on the routing map. Show all existing transmission facilities located in the study area. Include the locations of radio transmitters and other electronic installations, airstrips, irrigated pasture or cropland, parks and recreational areas, historical and archeological sites (subject to the instructions in Question 27), and any environmentally sensitive areas (subject to the instructions in Question 29).**

**Provide aerial photographs of the study area displaying the date that the photographs were taken or maps that show (1) the location of each route with each route segment identified, (2) the locations of all major public roads including, as a minimum, all federal and state roadways, (3) the locations of all known habitable structures or groups of habitable structures (see Question 19 below) on properties directly affected by any route, and (4) the boundaries (approximate or estimated according to best available information if required) of all properties directly affected by any route.**

**For each route, cross-reference each habitable structure (or group of habitable structures) and directly affected property identified on the maps or photographs with a list of corresponding landowner names and addresses and indicate which route segment affects each structure/group or property.**

**Base Maps**

Figures 3-14a, b, and c of the EA (Appendix D), titled *Primary Alternative Routes*, produced at a scale of 1 inch = 3,000 feet, are provided in map pockets in the EA. These maps were produced using a USGS topographic base. They depict the study area for the project, locations of radio transmitters and other electronic installations, airports/airstrips, parks and recreational areas, historical sites, environmentally sensitive areas and other

**JOINT APPLICATION OF LCRA TRANSMISSION SERVICES CORPORATION AND AEP TEXAS INC  
TO AMEND THEIR CERTIFICATES OF CONVENIENCE AND NECESSITY FOR THE BAKERSFIELD  
TO SOLSTICE 345-KV TRANSMISSION LINE PROJECT IN PECOS COUNTY, TEXAS**

---

constraints. The maps also contain the alternative routes for the project. For their protection, locations of archaeological sites are not shown on the maps.

Figures 4-1a, b, and c of the EA (Appendix E), titled *Habitable Structures and Other Land Use Features in the Vicinity of the Alternative Routes*, which consists of aerial photography produced at a scale of 1 inch = 3,000 feet, are provided in a map pocket in the EA. The aerial photo-based maps include parcel boundaries identified from a review of the tax appraisal district records and combined, as appropriate, to reflect instances where multiple parcels are owned by a single individual or group in the study area. The locations of all known habitable structures located within 500 feet of the centerline of primary alternative routes on properties directly affected by the project are also identified on Figures 4-1a, b, and c. The habitable structures and other land use features map (Figures 4-1a, b, and c) was produced using aerial imagery flown in February 2018.

Base maps include sufficient cultural and natural features to permit location of the alternative routes in the field, and they depict existing electric transmission lines and substations (based on information available to POWER), and major public roads located within the study area, as applicable.

A map showing the study area and all preliminary route segments in a format similar to EA Figures 3-14a, b, c and 4-1a, b, c was presented at the public open house meeting. Figure 3-1 depicts the preliminary route segments presented at the open house.

**Directly Affected Property Maps**

Attachment 4 to this application includes 10 maps (utilizing aerial photography) titled *Location of Directly Affected Parcels and Habitable Structures*, that identify directly affected properties, tract IDs, and the location of habitable structures (including labels) within approximately 500 feet of the centerline of the transmission line alternatives and approximate parcel boundary lines (based on tax appraisal district records). These maps show the location of each proposed alternative route with each route segment identified, and the locations of all major public roads including all federal and state roadways.

Attachment 6 to this Application is a list that cross-references each habitable structure, or group of habitable structures, and directly affected properties identified on the maps provided in Attachment 4 with a list of tract IDs and corresponding landowner names and addresses. Landowner names and addresses were obtained by review of information obtained from the Pecos County Appraisal District.

**20. Permits:**

**List any and all permits and/or approvals required by other governmental agencies for the construction of the proposed project. Indicate whether each permit has been obtained.**

Upon approval of the Application by the PUC, the following permits/approvals would be required and obtained prior to the commencement of construction:

- Where the proposed transmission line crosses a state-maintained road or highway, LCRA TSC and AEP Texas will obtain a permit from Texas Department of Transportation (TxDOT). If any portion of the transmission line will be accessed from a state-maintained road or highway, LCRA TSC and AEP Texas will obtain a permit from TxDOT.
- Where the transmission line crosses a state-owned riverbed or navigable stream, LCRA TSC and AEP Texas will obtain a Miscellaneous Easement (ME) from the General Land Office (GLO).
- Since more than one acre will be disturbed during construction of the project, a Storm Water Pollution Prevention Plan (SWPPP) will be necessary. Further, because more than five acres will be disturbed, a Notice of Intent (NOI) will be prepared by LCRA TSC and AEP Texas for the Texas Commission on Environmental Quality (TCEQ). The controls specified in the SWPPP will be monitored in the field.
- Upon approval of the Application and prior to construction, a detailed Natural Resources Assessment (NRA) and Cultural Resources Assessment (CRA) will be performed on the approved route. Depending upon the results of these assessments, permits or regulatory approvals may be required from the U.S. Army Corps of Engineers (USACE), USFWS, TCEQ, THC/SHPO or Pecos County. Such permits or regulatory approvals will be obtained by LCRA TSC and AEP Texas prior to construction.
- After alignments and structure locations/heights are designed and engineered, LCRA TSC and AEP Texas will make a final determination of the need for Federal Aviation Administration (FAA) notification, based on structure locations and designs. In some areas, if necessary, LCRA TSC and AEP Texas could use lower-than-typical structure heights and could add marking and/or lighting to certain structures to avoid or accommodate FAA requirements.
- LCRA TSC and AEP Texas will report the status of the Proposed Project to the PUC on LCRA TSC and AEP Texas' Monthly Construction Progress Report, beginning with the first report following the filing of a CCN application, and in each subsequent monthly progress report until construction is completed and actual project costs have been reported. As required by the PUC, LCRA TSC and AEP Texas will submit locational and attribute data for the approved route after it is constructed.

**JOINT APPLICATION OF LCRA TRANSMISSION SERVICES CORPORATION AND AEP TEXAS INC  
TO AMEND THEIR CERTIFICATES OF CONVENIENCE AND NECESSITY FOR THE BAKERSFIELD  
TO SOLSTICE 345-KV TRANSMISSION LINE PROJECT IN PECOS COUNTY, TEXAS**

---

**21. Habitable structures:**

For each route list all single-family and multi-family dwellings and related structures, mobile homes, apartment buildings, commercial structures, industrial structures, business structures, churches, hospitals, nursing homes, schools, or other structures normally inhabited by humans or intended to be inhabited by humans on a daily or regular basis within 300 feet of the centerline if the proposed project will be constructed for operation at 230kV or less, or within 500 feet of the centerline if the proposed project will be constructed for operation at greater than 230kV. Provide a general description of each habitable structure and its distance from the centerline of the route. In cities, towns or rural subdivisions, houses can be identified in groups. Provide the number of habitable structures in each group and list the distance from the centerline of the route to the closest and the farthest habitable structure in the group. Locate all listed habitable structures or groups of structures on the routing map.

The locations of habitable structures within 500 feet of the centerline of each route segment are listed and described with approximate distance from the route segment centerline in Appendix C, Tables 4-3 through 4-27 of the EA and are shown on Figures 4-1a, b, and c in Appendix E of the EA. The total numbers of habitable structures for the 25 primary alternative routes are provided in the table below.

<b>Primary Alternative Route</b>	<b>Total Number of Habitable Structures within 500 feet of the ROW Centerline</b>
<b>1</b>	5
<b>2</b>	5
<b>3</b>	11
<b>4</b>	2
<b>5</b>	8
<b>6</b>	11
<b>7</b>	10
<b>8</b>	5
<b>9</b>	5
<b>10</b>	0
<b>11</b>	5
<b>12</b>	0
<b>13</b>	0
<b>14</b>	2

**JOINT APPLICATION OF LCRA TRANSMISSION SERVICES CORPORATION AND AEP TEXAS INC  
TO AMEND THEIR CERTIFICATES OF CONVENIENCE AND NECESSITY FOR THE BAKERSFIELD  
TO SOLSTICE 345-KV TRANSMISSION LINE PROJECT IN PECOS COUNTY, TEXAS**

<b>Primary Alternative Route</b>	<b>Total Number of Habitable Structures within 500 feet of the ROW Centerline</b>
<b>15</b>	2
<b>16</b>	2
<b>17</b>	8
<b>18</b>	0
<b>19</b>	0
<b>20</b>	0
<b>21</b>	0
<b>22</b>	0
<b>23</b>	14
<b>24</b>	5
<b>25</b>	2

**22. Electronic Installations:**

**For each route, list all commercial AM radio transmitters located within 10,000 feet of the center line of the route, and all FM radio transmitters, microwave relay stations, or other similar electronic installations located within 2,000 of the center line of the route. Provide a general description of each installation and its distance from the center line of the route. Locate all listed installations on a routing map.**

There are no known commercial AM radio transmitters located within 10,000 feet of any of the primary alternative routes. There are seven known communication towers (FM radio transmitters, microwave towers, or other similar electronic installations) that are located within 2,000 feet of any of the primary alternative routes.

A listing, description, and approximate distance from the centerline of each of the primary alternative routes are presented in Table 4-29 and Appendix C, Tables 4-3 through 4-27 of the EA, and the locations of these electronic installations are shown on Figures 3-14a, b, c and 4-1a, b, c, in Appendix D and E of the EA.

For additional information on electronic installations see Section 2.4.6 and Section 4.2.4 of the EA. None of the routes filed in this Application are anticipated to have any impact on the existing communication towers.

**23. Airstrips:**

**For each route, list all known private airstrips within 10,000 feet of the center line of the project. List all airports registered with the Federal Aviation Administration (FAA) with at least one runway more than 3,200 feet in length that are located within 20,000 feet of the center line of any route. For each such airport, indicate whether any transmission structures will exceed a 100:1 horizontal slope (one foot in height for each 100 feet in distance) from the closest point of the closest runway. List all listed airports registered with the FAA having no runway more than 3,200 feet in length that are located within 10,000 feet of the center line of any route. For each such airport, indicate whether any transmission structures will exceed a 50:1 horizontal slope from the closest point of the closest runway. List all heliports located within 5,000 feet of the center line of any route. For each such heliport, indicate whether any transmission structures will exceed a 25:1 horizontal slope from the closest point of the closest landing and takeoff area of the heliport. Provide a general description of each listed private airstrip, registered airport, and heliport; and state the distance of each from the center line of each route. Locate and identify all listed airstrips, airports, and heliports on a routing map.**

POWER's review of federal and state aviation/airport maps and directories, aerial photo interpretation and reconnaissance surveys, identified one (1) FAA-registered airport, and no public-use heliports located within 5,000 feet of the centerline of any alternate route since there are no heliports located within or near the study area. According to initial analysis (the final heights of specific structures have not yet been determined), transmission structures may penetrate a 100:1 slope around the Fort Stockton-Pecos County Airport (runway length: 4,400 feet). Three private airstrips were identified within 10,000 feet of the centerline of one or more primary alternative routes.

Each airport/airstrip is listed and described with the approximate distance from the centerline of each of the primary alternative routes in Table 4-28 and Appendix C, Tables 4-3 through 4-27 of the EA. These facilities are shown on Figures 3-14a, b, c and 4-1a, b, c in Appendix D and E of the EA.

For additional information on airports/airstrips see Section 2.4.6 and Section 4.2.4 of the EA. No significant impacts to these airports/airstrips are anticipated from construction of the Proposed Project. Following approval of a route by the PUC, LCRA TSC and AEP Texas will make a final determination of the need for FAA notification, based on specific route location and structure design. The result of this notification, and any subsequent coordination with FAA, could include changes in the line design and/or potential requirements to mark and/or light the structures.

**24. Irrigation Systems:**

**For each route identify any pasture or cropland irrigated by traveling irrigation systems (rolling or pivot type) that will be traversed by the route. Provide a description of the irrigated land and state how it will be affected by each route (number and type of structures etc.). Locate any such irrigated pasture or cropland on a routing map.**

Based on POWER's review of aerial photography and field reconnaissance, no primary alternative route of the Proposed Project crosses any known cropland or pastureland irrigated by traveling irrigation systems, either rolling or pivot type.

**25. Notice:**

**Notice is to be provided in accordance with 16 TAC § 22.52.**

**A. Provide a copy of the written direct notice to owners of directly affected land. Attach a list of the names and addresses of the owners of directly affected land receiving notice.**

A copy of the written notice, with enclosures, that is being mailed to owners of directly affected land is included as Attachment 5 to the Application. A list of the names and addresses of those owners of directly affected land to whom notice was mailed by first-class mail is included as Attachment 6 to the Application. LCRA TSC and AEP Texas determined the names of the landowners of record and their mailing addresses based on information obtained from the Pecos County Appraisal District.

**B. Provide a copy of the written notice to utilities that are located within five miles of the routes.**

A copy of the written notice, with enclosures, sent to utilities that are located within five miles of the Project is provided in Attachment 7 to the Application. Additionally, LCRA TSC and AEP Texas sent notice of the Application to owners/operators of steel hydrocarbon pipelines and railroads parallel and adjacent to a primary alternative route included in the Application. A list of the names and addresses of utilities, pipeline owners/operators, and railroads to whom written notice was sent are included in Attachment 8 to the Application.

**C. Provide a copy of the written notice to county and municipal authorities.**

A copy of the written notice, with enclosures, sent to county and municipal authorities is provided as Attachment 7 to this Application. LCRA TSC and AEP Texas additionally sent notice of the Application to the Texas Office of Public Utility Counsel, independent school district officials, the Department of Defense



JOINT APPLICATION OF LCRA TRANSMISSION SERVICES CORPORATION AND AEP TEXAS INC  
TO AMEND THEIR CERTIFICATES OF CONVENIENCE AND NECESSITY FOR THE BAKERSFIELD  
TO SOLSTICE 345-KV TRANSMISSION LINE PROJECT IN PECOS COUNTY, TEXAS

---

Siting Clearinghouse, and state and federal elected officials (identified in Attachment 8).

- D. Provide a copy of the notice that is to be published in newspapers of general circulation in the counties in which the facilities are to be constructed. Attach a list of the newspapers that will publish the notice for this application. After the notice is published, provide the publisher's affidavits and tear sheets.**

A copy of the public notice that will be published in *The Fort Stockton Pioneer* (a newspaper of general circulation in Pecos County where the transmission facilities are to be constructed) once for one week after the Application is filed with the Commission is included as Attachment 9 to the Application. Publisher's affidavits will be filed with the Commission showing proof of notice as soon as available after filing of the Application.

**For a CREZ application, in addition to the requirements of P.U.C. PROC. R. 22.52 the applicant shall, not less than twenty-one (21) days before the filing of the application, submit to the Commission staff a "generic" copy of each type of alternative published and written notice for review. Staff's comments, if any, regarding the alternative notices will be provided to the applicant not later than seven days after receipt by Staff of the alternative notices, Applicant may take into consideration any comments made by Commission staff before the notices are published or sent by mail.**

Not applicable.

**26. Parks and Recreation Areas:**

**For each route, list all parks and recreational areas owned by a governmental body or an organized group, club, or church and located within 1,000 feet of the center line of the route. Provide a general description of each area and its distance from the center line. Identify the owner of the park or recreational area (public agency, church, club, etc.). List the sources used to identify the parks and recreational areas. Locate the listed sites on a routing map.**

POWER reviewed U.S. Geological Survey topographic maps, TxDOT county highway maps, recent aerial photography, and conducted field reconnaissance to identify parks and recreation areas within the study area. Based on this review, POWER identified five parks or recreational areas located within 1,000 feet of the centerline of one or more of the primary alternative routes.

A listing, description, and approximate distance from the centerline for each of the primary alternative routes are presented in Table 4-30 and Appendix C, Tables 4-3

through 4-27 of the EA and the locations of these parks and recreation areas are shown on Figures 3-14a, b, c and 4-1a, b, c, in Appendix D and E of the EA.

For more information on parks and recreational areas see Section 2.4.7 and Section 4.2.5 of the EA. No significant impacts to the use or enjoyment of the parks and recreation facilities located within the study area are anticipated from any of the primary alternative routes.

**27. Historical and Archeological Sites:**

**For each route, list all historical and archeological sites known to be within 1,000 feet of the center line of the route. Include a description of each site and its distance from the center line. List the sources (national, state or local commission or societies) used to identify the sites. Locate all historical sites on a routing map. For the protection of the sites, archeological sites need not be shown on maps.**

POWER conducted a literature review and records search at the Texas Historical Commission and The Texas Archeological Research Laboratory at the University of Texas at Austin to identify known historical and archeological sites located within 1,000 feet of the centerline of each of the primary alternate routes. For more information regarding site descriptions and the evaluation of the historical and archeological sites located within the study area, see Section 2.7 and Section 4.3 of the EA.

Based on POWER's review, 37 recorded archeological sites are located within 1,000 feet of the centerline of one or more of the primary alternative routes. Ten of the identified sites are crossed by the primary alternative route ROWs. Thirty-two of the sites are recorded as prehistoric sites, three are recorded as historic sites, and two of the sites have both prehistoric and historic components. These sites are listed and described with the approximate distance from the centerline for each of the primary alternative routes in Table 4-31 and Appendix C, Tables 4-3 through 4-27 of the EA. For the protection of these sites, they are not shown on the routing maps.

**28. Coastal Management Program:**

**For each route, indicate whether the route is located, either in whole or in part, within the coastal management program boundary as defined in 31 T.A.C. §503.1. If any route is, either in whole or in part, within the coastal management program boundary, indicate whether any part of the route is seaward of the Coastal Facilities Designation Line as defined in 31 T.A.C. §19.2(a)(21). Using the designations in 31 T.A.C. §501.3(b), identify the type(s) of Coastal Natural Resource Area(s) impacted by any part of the route and/or facilities.**

No part of any primary alternative route is located within the Coastal Management Program boundary, as defined in 31 TAC § 503.1.

**29. Environmental Impact:**

Provide copies of any and all environmental impact studies and/or assessments of the project. If no formal study was conducted for this project, explain how the routing and construction of this project will impact the environment. List the sources used to identify the existence or absence of sensitive environmental areas. Locate any environmentally sensitive areas on a routing map. In some instances, the location of the environmentally sensitive areas or the location of protected or endangered species should not be included on maps to ensure preservation of the areas or species. Within seven days after filing the application for the project, provide a copy of each environmental impact study and/or assessment to the Texas Parks and Wildlife Department (TPWD) for its review at the address below. Include with this application a copy of the letter of transmittal with which the studies/assessments were or will be sent to the TPWD.

Wildlife Habitat Assessment Program  
Wildlife Division  
Texas Parks and Wildlife Department  
4200 Smith School Road  
Austin, Texas 78744

**The applicant shall file an affidavit confirming that the letter of transmittal and studies/assessments were sent to TPWD.**

The EA describes the natural resources, cultural resources, land uses, and other sensitive areas that may occur within the study area. The EA also describes how the Project may impact such resources. Specifically, the EA includes data obtained from TPWD, including the Texas Natural Diversity Database (TXNDD) and a list of Ecologically Significant Stream Segments (ESSS) in the study area.

LCRA TSC and AEP Texas will provide a copy of the EA to TPWD within seven days after the Application is filed. A copy of the letter of transmittal of the EA to TPWD is provided as Attachment 10 to this Application. An affidavit confirming that the letter of transmittal and a copy of the EA were sent to TPWD will be filed with the Commission.

**30. Affidavit**

*Attach a sworn affidavit from a qualified individual authorized by the applicant to verify and affirm that, to the best of their knowledge, all information provided, statements made, and matters set forth in this application and attachments are true and correct.*

A sworn affidavit is attached below.

**AFFIDAVIT OF SONYA STRAMBLER**

**STATE OF TEXAS**

§  
§  
§

Before me, the undersigned authority, Sonya Strambler, being first duly sworn, deposes and states:

“My name is Sonya Strambler. I am a Regulatory Case Manager for the Lower Colorado River Authority. I am over the age of twenty-one, and am competent to make the following affidavit:

On behalf of LCRA Transmission Services Corporation (LCRA TSC) and in my capacity as Regulatory Case Manager on the Bakersfield to Solstice 345-kV Transmission Line Project, I am authorized to file and verify the CCN Application for LCRA TSC. I am personally familiar with the documents filed with this application, and I have complied with all the requirements contained in the application; furthermore, all such statements made and matters set forth herein with respect to LCRA TSC are true and correct.”

Sonya Strambler  
Sonya Strambler  
Affiant

SUBSCRIBED AND SWORN TO BEFORE ME, a Notary Public in and for the State of Texas, this 15<sup>th</sup> day of November, 2018.

Leagina Eddy  
Notary Public

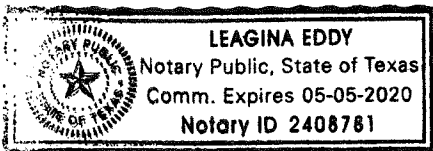

**AFFIDAVIT OF BRENT W HARRIS**

**STATE OF OKLAHOMA**                   §  
   §  
**COUNTY OF TULSA**                   §

Before me, the undersigned authority, Brent W. Harris, being first duly sworn, deposes and states:

“My name is Brent W. Harris. I am a Project Manager Principle (Project Manager) employed by American Electric Power Company (AEPSC) in the Transmission Services Department for ERCOT, which provides engineering, construction, and project management services to AEP Texas Inc. (AEP Texas). I am over the age of twenty-one, and am competent to make the following affidavit. On behalf of AEP Texas and in my capacity as the AEPSC Project Manager representing AEP Texas on the Bakersfield to Solstice 345-kV Transmission Line Project, I am qualified and authorized to file and verify such application on behalf of AEP Texas, am personally familiar with the maps and exhibits filed with this application, and have complied with all the requirements contained in the application; and, that all statements made and matters set forth therein and all exhibits attached thereto by AEP Texas are true and correct. I further state that the application is made in good faith, that notice of its filing is being provided in accordance with 16 TAC §25.174, and that this application does not duplicate any filing presently before the Commission.”

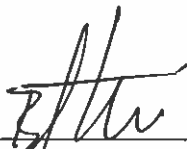
  
\_\_\_\_\_  
Brent W. Harris  
Project Manager Principle  
AEPSC

SUBSCRIBED AND SWORN TO BEFORE ME, a Notary Public in and for the State of

Oklahoma, this 1<sup>st</sup> day of Nov, 2018.

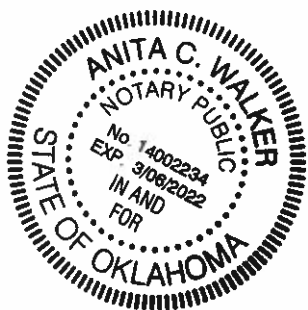

  
\_\_\_\_\_  
Notary Public State of Oklahoma

My Commission Expires: March 6, 2022