

**APPLICATION OF LCRA TRANSMISSION  
SERVICES CORPORATION TO AMEND ITS  
CERTIFICATE OF CONVENIENCE AND  
NECESSITY FOR THE PROPOSED MOUNTAIN  
HOME 138-KV TRANSMISSION LINE PROJECT IN  
GILLESPIE, KERR & KIMBLE COUNTIES, TEXAS**

**DOCKET NO. 49523**

*Submit seven (7) copies of the application and all attachments supporting the application. If the application is being filed pursuant to 16 Tex. Admin. Code § 25.101(b)(3)(D) (TAC) or 16 TAC § 25.174, include in the application all direct testimony. The application and other necessary documents shall be submitted to:*

**Public Utility Commission of Texas**

**Attn: Filing Clerk**

**1701 N. Congress Ave.**

**Austin, Texas 78711-3326**

**APPLICATION OF LCRA TRANSMISSION SERVICES CORPORATION  
TO AMEND ITS CERTIFICATE OF CONVENIENCE AND NECESSITY  
FOR THE PROPOSED MOUNTAIN HOME 138-KV TRANSMISSION LINE PROJECT IN  
GILLESPIE, KERR, AND KIMBLE COUNTIES, TEXAS**

---

Note: As used herein, the term “joint application” refers to an application for proposed transmission facilities for which ownership will be divided. All applications for such facilities should be filed jointly by the proposed owners of the facilities.

**1. Applicant (Utility) Name:** LCRA Transmission Services Corporation (LCRA TSC)

Certificate Number: 30110

Street Address: 3700 Lake Austin Boulevard  
Austin, TX 78703

Mailing Address: P.O. Box 220  
Austin, TX 78767-0220

**2. Please identify all entities that will hold an ownership interest or an investment interest in the proposed project but which are not subject to the Commission’s jurisdiction.**

LCRA TSC will hold the sole ownership interest in the project that is the subject of this Application. No entities will hold an ownership or investment interest in the project that are not subject to the jurisdiction of the Public Utility Commission of Texas (PUC or Commission).

**3. Person to Contact:** Lance Wenmohs  
Title/Position: Manager, Siting & Certification  
Phone Number: (512) 578-4495  
Mailing Address: P.O. Box 220  
Mail Stop DSC D204  
Austin, TX 78767-0220

Email Address: [lance.wenmohs@lcra.org](mailto:lance.wenmohs@lcra.org)

**Alternate Contact:** Don Kiser  
Title/Position: Sr. Director, Regulatory Affairs  
Phone Number: (512) 578-7581  
Mailing Address: P.O. Box 220  
Mail Stop S520  
Austin, TX 78767-0220

Email Address: [don.kiser@lcra.org](mailto:don.kiser@lcra.org)

**APPLICATION OF LCRA TRANSMISSION SERVICES CORPORATION  
TO AMEND ITS CERTIFICATE OF CONVENIENCE AND NECESSITY  
FOR THE PROPOSED MOUNTAIN HOME 138-KV TRANSMISSION LINE PROJECT IN  
GILLESPIE, KERR, AND KIMBLE COUNTIES, TEXAS**

---

**Legal Counsel:** Kirk Rasmussen  
**Phone Number:** (512) 615-1203  
**Mailing Address:** Enoch Keever PLLC  
5918 W. Courtyard Dr., Suite 500  
Austin, TX 78730  
**Email Address:** kasmussen@enochkeever.com

**4. Project Description:**

**Name or Designation of Project**

Mountain Home 138-kV Transmission Line Project in Gillespie, Kerr, and Kimble Counties, Texas (the Proposed Project).

**Provide a general description of the project, including the design voltage rating (kV), the operating voltage (kV), the CREZ Zone(s) (if any) where the project is located (all or in part), any substations and/or substation reactive compensation constructed as part of the project, and any series elements such as sectionalizing switching devices, series line compensation, etc. For HVDC transmission lines, the converter stations should be considered to be project components and should be addressed in the project description.**

**If the project will be owned by more than one party, briefly explain the ownership arrangements between the parties and provide a description of the portion(s) that will be owned by each party. Provide a description of the responsibilities of each party for implementing the project (design, Right-of-Way acquisition, material procurement, construction, etc.).**

**If applicable, identify and explain any deviation in transmission project components from the original transmission specifications as previously approved by the Commission or recommended by a PURA §39.151 organization.**

**General Description of Project**

The Proposed Project is a new 138-kilovolt (kV) transmission line located in southwestern Gillespie County, northeastern Kerr County and a portion of southeastern Kimble County, depending on the route selected. The Proposed Project consists of constructing one new substation (Mountain Home) and a new 138-kV transmission line connecting the new Mountain Home Substation to the electric grid at either the existing Hunt Substation or Ingram Substation and at the existing Harper Substation. The Mountain Home Substation will be near the community of Mountain Home. The new transmission line will be approximately 21.5 to 29.8 miles long, depending on the route selected.

**APPLICATION OF LCRA TRANSMISSION SERVICES CORPORATION  
TO AMEND ITS CERTIFICATE OF CONVENIENCE AND NECESSITY  
FOR THE PROPOSED MOUNTAIN HOME 138-KV TRANSMISSION LINE PROJECT IN  
GILLESPIE, KERR, AND KIMBLE COUNTIES, TEXAS**

---

Along most alternate segments, the Proposed Project will be constructed on single-circuit pole structures. If Segments X3, B, F, or E4 are part of the PUC approved route, these segments will be constructed on double-circuit 138-kV poles containing the new 138-kV circuit from Hunt or Ingram to Mountain Home and the existing LCRA TSC 138-kV circuit connecting Hunt to Ingram (T487). LCRA TSC is seeking certification and PUC approval for the new 138-kV circuit from Hunt or Ingram to Mountain Home to Harper in this Application.

To connect each end of the new transmission line to the existing electric transmission system, the existing Harper Substation will be expanded and upgraded to include a new 138-kV bus with breakers and a 138/69-kV autotransformer.

Please see Figure 1-1 in the *Mountain Home 138-kV Transmission Line Project Environmental Assessment and Alternative Route Analysis Gillespie, Kerr and Kimble Counties, Texas* (EA), incorporated herein by reference for all purposes and included as Attachment 1 to this Application, which shows the Mountain Home area and the location of the Proposed Project end points.

The Proposed Project is not located, all or in part, within a Competitive Renewable Energy Zone (CREZ). No substation reactive compensation and no series elements such as sectionalizing switching devices or series line compensation will be constructed as part of the Proposed Project.

**Ownership Arrangements**

LCRA TSC will design, procure, construct, operate, and maintain all transmission line facilities for the Proposed Project, including all conductors, wires, structures, hardware, and rights-of-way (ROW). LCRA TSC will also design, operate, construct, and maintain the transmission facilities at the new proposed electric load-serving Mountain Home Substation.

To connect each end of the new transmission line to the existing electric grid, LCRA TSC will install terminal equipment at the existing Hunt or Ingram and Harper Substations.

**Deviation from original PURA §39.151 organization (ERCOT)**

LCRA TSC and Central Texas Electric Cooperative (CTEC) submitted the Proposed Project to the Electric Reliability Council of Texas (ERCOT) Regional Planning Group (RPG) for review and received comments on the Proposed Project from Kerrville Public Utility Board (K PUB), which were supportive of the project. Following RPG review, ERCOT staff determined that the Proposed Project would not result in any violation of North American Electric Reliability Corporation (NERC) or ERCOT performance requirements and classified the Proposed Project as “Tier 4 Neutral,” based on its

**APPLICATION OF LCRA TRANSMISSION SERVICES CORPORATION  
TO AMEND ITS CERTIFICATE OF CONVENIENCE AND NECESSITY  
FOR THE PROPOSED MOUNTAIN HOME 138-KV TRANSMISSION LINE PROJECT IN  
GILLESPIE, KERR, AND KIMBLE COUNTIES, TEXAS**

---

objective of meeting the reliability needs of CTEC and LCRA TSC planning criteria for load-serving substation reliability. Correspondence with ERCOT regarding the Proposed Project is included as Attachment 2. The Proposed Project endpoints (Hunt or Ingram and Harper substations) included in this Application do not deviate from those provided to ERCOT.

5. **Conductor and Structures:**
- |   |                             |
|---|-----------------------------|
| <b>Conductor Size and Type:</b>   | 795 Kcmil 26/7 ACSR “Drake” |
| <b>Number of conductors per phase:</b>                                    | One (1) conductor per phase |
| <b>Continuous Summer Static Current Rating (A):</b>                       | 930 A                       |
| <b>Continuous Summer Static Line Capacity at Operating Voltage (MVA):</b> | 220 MVA                     |
| <b>Continuous Summer Static Line Capacity at Design Voltage (MVA):</b>    | 220 MVA                     |
- Type and Composition of Structures:**
- LCRA TSC proposes to use 138-kV single-circuit capable steel and/or concrete pole structures for typical tangent, angle, and deadend structures. Note that for some segments (X3, B, F and E4), LCRA TSC could rebuild its existing Hunt to Ingram 138-kV electric transmission line (T487) located in the southern portion of the study area. If this existing 138-kV transmission line is rebuilt, double circuit steel or concrete pole structures would be required.
- Height of Typical Structures:**
- The heights of typical structures proposed for the project range from 80 to 120 feet above ground.

**APPLICATION OF LCRA TRANSMISSION SERVICES CORPORATION  
TO AMEND ITS CERTIFICATE OF CONVENIENCE AND NECESSITY  
FOR THE PROPOSED MOUNTAIN HOME 138-KV TRANSMISSION LINE PROJECT IN  
GILLESPIE, KERR, AND KIMBLE COUNTIES, TEXAS**

---

**Explain why these structures were selected; include such factors as landowner preference, engineering considerations, and costs comparisons to alternate structures that were considered. Provide dimensional drawings of the typical structures to be used in the project.**

LCRA engineers selected steel and/or concrete poles as the structure type for the Proposed Project. Steel and/or concrete poles are the least-cost structure alternative, generally require a smaller footprint, and are typically the most favored structure type by landowners. The determination of material type (pre-stressed concrete or steel) will be made during the detailed design phase of the project, considering factors such as engineering constraints, cost, and schedule. For a detailed discussion of the proposed typical structures and their requirements please refer to Section 1.4.2 of the EA.

Routes that include segments X3, B, F, and E4 would require rebuilding an existing LCRA TSC single-circuit 138-kV electric transmission line (T487 Hunt to Ingram, depending upon the specific route segment) partially within an existing easement. Utilizing an existing transmission line ROW requires that the structures be capable of holding two 138-kV electric circuits, the existing circuit connecting Hunt to Ingram (T487) and the new circuit connecting Hunt or Ingram to the new Mountain Home Substation. Therefore, these segments will require the use of new double-circuit capable single-pole structures.

Please refer to Figures 1-2 through 1-7 in the EA for drawings of the typical structures proposed to be used in this project.

**For joint applications, provide and separately identify the above-required information regarding structures for the portion(s) of the project owned by each applicant.**

This is not a joint application.

**APPLICATION OF LCRA TRANSMISSION SERVICES CORPORATION  
TO AMEND ITS CERTIFICATE OF CONVENIENCE AND NECESSITY  
FOR THE PROPOSED MOUNTAIN HOME 138-KV TRANSMISSION LINE PROJECT IN  
GILLESPIE, KERR, AND KIMBLE COUNTIES, TEXAS**

---

- 6. Right-of-way:**
- Miles of Right-of-Way:** Approximately 21.5 to 29.8 miles
- Miles of Circuit:** Approximately 21.5 to 29.8 miles
- Width of Right-of-Way:** The typical ROW width for the Proposed Project is estimated to be 100 feet.
- Percent of Right-of-Way Acquired:** The percent of the ROW acquired for the Proposed Project at this time varies from 0 to approximately 18 percent for routes Ingram 8, 9 and 10, which use Segment E4. Routes to Hunt vary from less than 1 to 5 percent ROW acquired. Routes Hunt 1, 2, 7 through 14, and 18 through 22, which use segments X3, B, and F, all have approximately 5 percent ROW acquired. The existing ROW available for use for some alternative routes on this project corresponds with existing LCRA TSC ROW located along its existing Hunt to Ingram 138-kV transmission line (T487). Please see the table below for the percent of ROW acquired for each of the alternative routes.

<b>Primary Alternative Route</b>	<b>Percent of Right-of-Way Acquired</b>	<b>Segments Utilizing Existing Right-of-Way</b>
<b>Hunt 1</b>	5	X3, B, F
<b>Hunt 2</b>	5	X3, B, F
<b>Hunt 3</b>	<1	X3, B
<b>Hunt 4</b>	<1	X3
<b>Hunt 5</b>	<1	X3, B
<b>Hunt 6</b>	<1	X3, B
<b>Hunt 7</b>	5	X3, B, F
<b>Hunt 8</b>	5	X3, B, F
<b>Hunt 9</b>	5	X3, B, F
<b>Hunt 10</b>	5	X3, B, F
<b>Hunt 11</b>	5	X3, B, F
<b>Hunt 12</b>	5	X3, B, F

**APPLICATION OF LCRA TRANSMISSION SERVICES CORPORATION  
TO AMEND ITS CERTIFICATE OF CONVENIENCE AND NECESSITY  
FOR THE PROPOSED MOUNTAIN HOME 138-KV TRANSMISSION LINE PROJECT IN  
GILLESPIE, KERR, AND KIMBLE COUNTIES, TEXAS**

<b>Hunt 13</b>	5	X3, B, F
<b>Hunt 14</b>	5	X3, B, F
<b>Hunt 15</b>	<1	X3, B
<b>Hunt 16</b>	<1	X3, B
<b>Hunt 17</b>	<1	X3, B
<b>Hunt 18</b>	5	X3, B, F
<b>Hunt 19</b>	5	X3, B, F
<b>Hunt 20</b>	5	X3, B, F
<b>Hunt 21</b>	5	X3, B, F
<b>Hunt 22</b>	5	X3, B, F
<b>Hunt 23</b>	<1	X3, B
<b>Hunt 24</b>	<1	X3, B
<b>Hunt 25</b>	<1	X3, B
<b>Hunt 26</b>	<1	X3
<b>Hunt 27</b>	<1	X3, B
<b>Hunt 28</b>	<1	X3, B
<b>Hunt 29</b>	<1	X3, B
<b>Hunt 30</b>	<1	X3, B
<b>Ingram 1</b>	0	NA
<b>Ingram 2</b>	0	NA
<b>Ingram 3</b>	0	NA
<b>Ingram 4</b>	0	NA
<b>Ingram 5</b>	0	NA
<b>Ingram 6</b>	0	NA
<b>Ingram 7</b>	0	NA
<b>Ingram 8</b>	18	E4
<b>Ingram 9</b>	18	E4
<b>Ingram 10</b>	18	E4



**APPLICATION OF LCRA TRANSMISSION SERVICES CORPORATION  
TO AMEND ITS CERTIFICATE OF CONVENIENCE AND NECESSITY  
FOR THE PROPOSED MOUNTAIN HOME 138-KV TRANSMISSION LINE PROJECT IN  
GILLESPIE, KERR, AND KIMBLE COUNTIES, TEXAS**

---

**For joint applications, provide and separately identify the above-required information for each route for the portion(s) of the project owned by each applicant.**

This is not a joint application.

**Provide a brief description of the area traversed by the transmission line. Include a description of the general land uses in the area and the type of terrain crossed by the line.**

The new transmission line will connect the existing Harper Substation to a new Mountain Home Substation and then to either the existing Hunt Substation or Ingram Substation. The area of the Proposed Project is located within Gillespie, Kerr, and Kimble counties, Texas and includes portions of the City of Ingram and some unincorporated communities. These communities include: Harper, Mountain Home, and Hunt.

Land uses within the project area include scattered residential areas and agricultural areas represented by pastureland, rangeland, and cropland. Project area pastures and rangeland are used to support cattle, goats, sheep, horses, wildlife (native and exotic) operations, and/or the production of hay. The primary crops grown within the project area include hay, sorghum, wheat, oats, and pecans.

The project area is situated within the Edwards Plateau physiographic region of Texas. The region's topography is characterized by flat upper surfaces, interspersed by drainages that open up into larger draws or box canyons. Elevations in the Edwards Plateau range between 3,000 feet above mean sea level (amsl) within the western and northern portions, to 450 feet amsl as you move towards the Gulf Coast. Elevations in the study area range between approximately 1,700 feet along Johnson Creek to about 2,200 feet amsl in the hills located in the southwestern portion of the study area.

Specific discussion regarding natural, human, and cultural resources in the project area is set forth in the EA, Section 2.0, pages 2-9 through 2-70.

**APPLICATION OF LCRA TRANSMISSION SERVICES CORPORATION  
TO AMEND ITS CERTIFICATE OF CONVENIENCE AND NECESSITY  
FOR THE PROPOSED MOUNTAIN HOME 138-KV TRANSMISSION LINE PROJECT IN  
GILLESPIE, KERR, AND KIMBLE COUNTIES, TEXAS**

---

**7. Substations or Switching Stations:**

**List the name of all existing HVDC converter stations, substations or switching stations that will be associated with the new transmission line. Provide documentation showing that the owner(s) of the existing HVDC converter stations, substations and/or switching stations have agreed to the installation of the required project facilities.**

The existing electric load-serving substations listed below are associated with the Proposed Project.

1. CTEC Harper Substation
2. LCRA TSC Hunt Substation
3. LCRA TSC Ingram Substation

The existing CTEC Harper Substation and either the existing Hunt or Ingram substations are the connecting points for the new transmission line to the existing electric grid. There are no HVDC converter stations associated with the Proposed Project.

Attachment 3 to this Application provides documentation demonstrating that CTEC, as the owner of the Harper Substation, is aware of the Proposed Project and has agreed to the installation of the required facilities associated with the interconnection of the Proposed Project.

**8. Estimated Schedule:**

<b><u>Estimated Dates of:</u></b>	<b><u>Start</u></b>	<b><u>Completion</u></b>
Right-of-way and Land Acquisition	July 2020	January 2022
Engineering and Design	July 2020	June 2021
Material and Equipment Procurement	May 2021	July 2021
Construction of Facilities	August 2021	December 2022
Energize Facilities	---	December 2022

**APPLICATION OF LCRA TRANSMISSION SERVICES CORPORATION  
TO AMEND ITS CERTIFICATE OF CONVENIENCE AND NECESSITY  
FOR THE PROPOSED MOUNTAIN HOME 138-KV TRANSMISSION LINE PROJECT IN  
GILLESPIE, KERR, AND KIMBLE COUNTIES, TEXAS**

---

**9. Counties:**

**For each route, list all counties in which the route is to be constructed.**

All of the 40 alternative routes included in this Application would be constructed in Gillespie and Kerr Counties.

The following routes would be constructed in Gillespie, Kerr, and Kimble Counties: Hunt 17, Hunt 21, Hunt 22, Hunt 26, and Hunt 30.

Please refer to Figures 4-24, 4-25a, 4-25b, 5-1a, and 5-1b in the EA for the location of alternative route segments.

**10. Municipalities:**

**For each route, list all municipalities in which the route is to be constructed.**

None of the alternative routes would be constructed within an incorporated municipality.

**For each applicant, attach a copy of the franchise, permit or other evidence of the city's consent held by the utility, if necessary or applicable. If franchise, permit, or other evidence of the city's consent has been previously filed, provide only the docket number of the application in which the consent was filed. Each applicant should provide this information only for the portion(s) of the project which will be owned by the applicant.**

Authority for LCRA TSC to provide transmission service within Gillespie, Kerr, and Kimble counties is contained in, among other dockets, Docket No. 24419.

**APPLICATION OF LCRA TRANSMISSION SERVICES CORPORATION  
TO AMEND ITS CERTIFICATE OF CONVENIENCE AND NECESSITY  
FOR THE PROPOSED MOUNTAIN HOME 138-KV TRANSMISSION LINE PROJECT IN  
GILLESPIE, KERR, AND KIMBLE COUNTIES, TEXAS**

**11. Affected Utilities:**

**Identify any other electric utility served by or connected to facilities in this application.**

CTEC owns the existing Harper Substation, which is one of the project end points and will be served by, and connected to, the facilities proposed for construction in this Application. CTEC has existing distribution feeders at the existing Ingram Substation. KPUB receives transmission service from LCRA TSC and owns the power transformers and distribution bus at the existing Hunt Substation and Ingram Substation. Bandera Electric Cooperative (BEC) owns facilities in the vicinity of the Proposed Project that will be positively affected by the project.

Location	Description	Affected Utility		
		CTEC	KPUB	BEC
Harper	End point for project	X		
Hunt	Possible end point for project		X	
Ingram	Possible end point for project	X	X	
	Relocate and underground distribution lines inside substation if Segment F4 is part of approved route		X	
	Relocate and underground distribution lines inside substation if Segment E4 is part of approved route	X		
Doss	Impacted during construction at Harper	X		
Harper Road	Benefits from third transmission source into Hunt or Ingram		X	
Jack Furman	Benefits from third transmission source into Hunt or Ingram	X	X	
Rim Rock	Benefits from third transmission source into Hunt or Ingram	X	X	
Turtle Creek	Benefits from third transmission source into Hunt or Ingram			X

**APPLICATION OF LCRA TRANSMISSION SERVICES CORPORATION  
TO AMEND ITS CERTIFICATE OF CONVENIENCE AND NECESSITY  
FOR THE PROPOSED MOUNTAIN HOME 138-KV TRANSMISSION LINE PROJECT IN  
GILLESPIE, KERR, AND KIMBLE COUNTIES, TEXAS**

---

**Describe how any other electric utility will be affected and the extent of the other utilities' involvement in the construction of this project. Include any other electric utilities whose existing facilities will be utilized for the project (vacant circuit positions, ROW, substation sites and/or equipment, etc.) and provide documentation showing that the owner(s) of the existing facilities have agreed to the installation of the required project facilities.**

CTEC owns the existing Harper Substation, which is the proposed northern end point to which the facilities proposed for construction in the Application would connect. LCRA TSC will expand and convert the Harper Substation for 138-kV operation as part of the Proposed Project. At the new Mountain Home Substation, CTEC will install a 138-kV power transformer to connect to the Proposed Project. CTEC will be served by and connected to the proposed Mountain Home Substation.

Electric service requirements for a large number of current and future end-use customers within the project area will be met by CTEC with the installation of the new electric load-serving substation (Mountain Home) associated with the Proposed Project. The new substation will provide the electrical source to supply existing and future electrical loads in the project area. The new electric load-serving substation will also increase the reliability of service to the broader area.

In addition, LCRA TSC and CTEC have filed an application at the PUC to transfer the existing 69-kV Harper to Live Oak transmission line (T288) from CTEC to LCRA TSC (Docket No. 49357). Following approval of the transfer by the PUC and completion of the Proposed Project, the existing 69-kV Harper to Live Oak transmission line (T288) will be upgraded to 138-kV.

KPUB provides distribution service out of the existing Hunt Substation and CTEC and KPUB both provide distribution service out of the existing Ingram Substation, which are the southern alternative end points to which the facilities proposed for construction in the Application would connect. If Segment F4 is included in the PUC approved route, LCRA TSC will relocate and underground some existing KPUB distribution lines located inside the Ingram Substation to accommodate construction of the new 138-kV transmission line from Ingram to Mountain Home. If Segment E4 is included in the PUC approved route, LCRA TSC will relocate and underground some existing CTEC distribution lines located inside the Ingram Substation to accommodate construction of the new 138-kV transmission line from Ingram to Mountain Home.

**APPLICATION OF LCRA TRANSMISSION SERVICES CORPORATION  
TO AMEND ITS CERTIFICATE OF CONVENIENCE AND NECESSITY  
FOR THE PROPOSED MOUNTAIN HOME 138-KV TRANSMISSION LINE PROJECT IN  
GILLESPIE, KERR, AND KIMBLE COUNTIES, TEXAS**

**12. Financing:**

**Describe the method of financing this project. For each applicant that is to be reimbursed for all or a portion of this project, identify the source and amount of the reimbursement (actual amount if known, estimated amount otherwise) and the portion(s) of the project for which the reimbursement will be made.**

LCRA TSC will finance the facilities included in the Application in a manner similar to that which has been used for projects previously constructed by LCRA TSC. Such financing may include a combination of tax-exempt commercial paper, tax-exempt private revolving note, or taxable commercial paper, and, subsequent to project completion, fixed-rate debt. Interest on the debt may be capitalized until the project is in service, at which point it is intended that both the principal and interest will be serviced with Transmission Cost of Service revenues.

LCRA TSC is the sole applicant, and, therefore, no other party will be reimbursed for any portion of the project.

**13. Estimated Costs: Provide cost estimates for each route of the proposed project using the following table. Provide a breakdown of “Other” costs by major cost category and amount. Provide the information for each route in an attachment to this application.**

	<u>Transmission Facilities *</u>	<u>Substation Facilities *</u>
Right-of-way and Land Acquisition		
Engineering and Design (Utility)		
Engineering and Design (Contract)		
Procurement of Material and Equipment (including stores)		
Construction of Facilities (Utility)		
Construction of Facilities (Contract)		
Other (all costs not included in the above categories)		
<b>Estimated Total Cost</b>	See Attach. 4	See Attach. 4

\*Please refer to Attachment 4 to this Application for Transmission and Substation Facilities estimated costs for each alternative route presented in this Application.

**APPLICATION OF LCRA TRANSMISSION SERVICES CORPORATION  
TO AMEND ITS CERTIFICATE OF CONVENIENCE AND NECESSITY  
FOR THE PROPOSED MOUNTAIN HOME 138-KV TRANSMISSION LINE PROJECT IN  
GILLESPIE, KERR, AND KIMBLE COUNTIES, TEXAS**

---

**14. Need for the Proposed Project:**

**For a standard application, describe the need for the construction and state how the proposed project will address the need. Describe the existing transmission system and conditions addressed by this application. For projects that are planned to accommodate load growth, provide historical load data and load projections for at least five years. For projects to accommodate load growth or to address reliability issues, provide a description of the steady state load flow analysis that justifies the project. For interconnection projects, provide any documentation from a transmission service customer, generator, transmission service provider, or other entity to establish that the proposed facilities are needed. For projects related to a Competitive Renewable Energy Zone, the foregoing requirements are not necessary; the applicant need only provide a specific reference to the pertinent portion(s) of an appropriate commission order specifying that the facilities are needed. For all projects, provide any documentation of the review and recommendation of a PURA §39.151 organization.**

**Describe the need for the construction and state how the proposed project will address the need. Describe the existing transmission system and conditions addressed by this application. For projects that are planned to accommodate load growth, provide historical load data and load projections for at least five years. For projects to accommodate load growth or to address reliability issues, provide a description of the steady state load flow analysis that justifies the project.**

Load growth at a compound annual growth rate of approximately 2 percent in western Gillespie and western Kerr Counties has resulted in a combined winter loading level in excess of 20 MW (approximately 10 percent of CTEC's consumer load) served by a single radial 69-kV transmission line extending from Fredericksburg to the communities of Harper and Doss. As of April 2, there were 4,692 consumers served by this radial transmission line including the entire communities of Harper and Doss, residential and commercial development along Interstate Highway (IH) 10 south of Harper, and the area extending to the Garven Store area. The absence of existing substations near the areas of higher consumer density along IH 10 has resulted in long and heavily loaded distribution feeders serving this area. Attachment 5 shows the consumer density and feeder loading resulting from the load growth in the area around Mountain Home. The load growth requires construction of a new load-serving substation in the Mountain Home area. Mountain Home is located along IH 10 west of Kerrville in the area of the intersection of State Highway 41 and State Highway 27 between Harper to the northeast and Garven Store to the southwest. A new 138-kV transmission line is needed in order to serve the new Mountain Home Substation since there are no existing 138-kV transmission lines within seven miles of the proposed substation location.

**APPLICATION OF LCRA TRANSMISSION SERVICES CORPORATION  
TO AMEND ITS CERTIFICATE OF CONVENIENCE AND NECESSITY  
FOR THE PROPOSED MOUNTAIN HOME 138-KV TRANSMISSION LINE PROJECT IN  
GILLESPIE, KERR, AND KIMBLE COUNTIES, TEXAS**

---

The Proposed Project addresses these needs by proposing construction of a new 138-kV transmission line from either Hunt or Ingram to provide a reliable source to the new Mountain Home Substation and extend a new 138-kV transmission line from the new Mountain Home Substation to the Harper Substation in order to provide a reliable source under single contingency events to the Mountain Home, Harper, and Doss substations, which represents more than 20 MW (approximately 10 percent of the CTEC's total load obligation).

The area addressed by the Proposed Project is primarily served by 1,100 miles of 25-kV distribution circuits connected to the transmission system at the Harper and Doss substations. A single, radial 21.6-mile 69-kV transmission line that extends from the Live Oak Substation (in Fredericksburg, Texas) provides transmission service to the Harper Substation and then extends another 14.2 miles from the Harper Substation to provide transmission service to the Doss Substation. The radial 69-kV transmission system serving the Harper and Doss substations is sourced from two 138/69-kV autotransformers located at the Fredericksburg and Gillespie substations.

A small portion of the area to the south and east of Mountain Home is served by 12-kV distribution circuits connected to the Ingram Substation. Transmission service is provided to the Ingram Substation by 138-kV transmission lines serving six existing substations (including the Ingram Substation). These 138-kV transmission lines are connected to the transmission network at the Kerrville Stadium Substation and the Verde Creek Substation.

A double-circuit 345-kV series compensated transmission line between the Big Hill Substation (in Schleicher County near San Angelo) and the Kendall Substation (in Kendall County near San Antonio) crosses through, but does not connect to any load-serving substation. As will be discussed further below, this series-compensated 345-kV line, constructed as part of the CREZ project, is not a viable alternative for providing transmission service directly to the proposed Mountain Home Substation.

Figure 16-1, included in response to Question 16 of this Application, is a one-line diagram of the existing transmission system and an illustration of the transmission system existing in and around the project area.

CTEC conducted an analysis of the distribution system serving the Mountain Home area (see the CTEC Harper Substation Distribution Alternative Study provided as Attachment 6 to this Application). The analysis applied the following CTEC system reliability planning criteria:

1. To maintain adequate consumer reliability which meets or exceeds present levels, individual feeder loading will be limited to 6 MW.



**APPLICATION OF LCRA TRANSMISSION SERVICES CORPORATION  
TO AMEND ITS CERTIFICATE OF CONVENIENCE AND NECESSITY  
FOR THE PROPOSED MOUNTAIN HOME 138-KV TRANSMISSION LINE PROJECT IN  
GILLESPIE, KERR, AND KIMBLE COUNTIES, TEXAS**

---

2. No more than 20 MW of peak load shall be interrupted for a single anticipated event.

The CTEC analysis determined that Feeder 3-2 and Feeder 3-3 at the Harper Substation will exceed the 6 MW criteria by the winter of 2020 (see Attachment 6 at Appendix A, Table 1).

In addition, Table 14-1, below, shows the winter loads that were projected by CTEC to exceed 20 MW (20,000 kW) at the radially served Harper and Doss substations by the winter of 2021.

**Table 14-1: CTEC Winter Peak Load Forecast for the Harper and Doss substations<sup>1</sup>**

BUS NUMBER	SUBSTATION	2019-2020 kW	2020-2021 kW
7410	Harper	16,329	16,843
7408	Doss	3,596	3,732
Total:		19,925	20,575

The CTEC report concluded that a new dually-served substation in the Mountain Home area was the best long-term solution to resolve the identified planning criteria violations. The load levels forecasted in the CTEC study in 2016 have been exceeded by actual levels over the past two years, demonstrating and confirming the reasonableness of the CTEC forecast.

---

<sup>1</sup> Based on CTEC Distribution Study dated June 27, 2016 (Attachment 6).

**APPLICATION OF LCRA TRANSMISSION SERVICES CORPORATION  
TO AMEND ITS CERTIFICATE OF CONVENIENCE AND NECESSITY  
FOR THE PROPOSED MOUNTAIN HOME 138-KV TRANSMISSION LINE PROJECT IN  
GILLESPIE, KERR, AND KIMBLE COUNTIES, TEXAS**

<b>TABLE 14-2: HISTORICAL WINTER PEAK LOAD DATA (kW)</b>											
<b>CTEC SUBSTATIONS</b>											
Location	2009	2010	2011	2012	2013	2014	2015	2016	2017	2018	2019*
<b>HARPER</b>	9,622	13,521	14,723	11,652	11,535	13,011	12,730	11,707	16,085	16,957	12,353
<b>DOSS</b>	1,857	2,924	3,355	2,421	2,275	3,343	2,678	2,788	3,786	3,959	3,027
<b>SUBTOTAL</b>	11,479	16,445	18,078	14,073	13,810	16,354	15,408	14,495	19,871	20,916	15,380
<b>KERRVILLE WEST LOOP SUBSTATION</b>											
Location	2009	2010	2011	2012	2013	2014	2015	2016	2017	2018	2019**
<b>HARPER ROAD</b>	23,926	31,880	32,157	24,493	24,594	27,237	24,875	22,439	27,511	28,593	21,372
<b>HUNT</b>	8,933	15,050	14,798	11,076	11,240	12,195	11,492	10,467	14,672	14,688	10,060
<b>INGRAM</b>	15,991	24,544	22,895	15,685	15,900	17,515	14,399	12,810	16,797	17,039	13,728
<b>JACK FURMAN</b>	0	0	411	5,223	4,976	5,780	6,909	6,153	8,086	8,096	7,747
<b>RIM ROCK</b>	16,027	23,444	25,922	19,657	18,671	21,732	19,209	17,188	22,976	23,110	17,666
<b>TURTLE CREEK</b>	10,225	15,389	15,619	12,216	11,653	14,335	12,396	10,730	15,618	16,037	11,611
<b>SUBTOTAL</b>	75,102	110,307	111,802	88,350	87,034	98,794	89,280	79,787	105,660	107,083	82,184

\* In 2019, the system peak occurred outside of the ERCOT defined Winter months. The peak was March 5, 2019 at 0715.

Harper - 14,633 kW and Doss - 3148 kW for a Subtotal of 17,781 kW Harper/Doss Substations.

\*\*2019, the system peak occurred outside of the ERCOT defined Winter months. The peak was March 5, 2019 at 0715.

Harper Road - 24,453 kW, Hunt - 12,243 kW, Ingram - 15,107 kW, Jack Furman - 7,151 kW, Rim Rock - 20,484 kW, Turtle Creek - 13,888 kW for a Subtotal of 93,326 kW in the Kerrville West Loop.

<b>Table 14-3: HISTORICAL SUMMER PEAK LOAD DATA (kW)</b>										
<b>CTEC SUBSTATIONS</b>										
Location	2009	2010	2011	2012	2013	2014	2015	2016	2017	2018
<b>HARPER</b>	10,605	10,827	11,821	11,278	11,836	11,248	12,123	12,769	13,337	11,616
<b>DOSS</b>	2,232	2,131	2,576	2,341	2,541	2,430	2,459	2,644	2,681	3,030
<b>SUBTOTAL</b>	12,837	12,958	14,397	13,619	14,377	13,678	14,582	15,413	16,018	14,646
<b>KERRVILLE WEST LOOP SUBSTATION</b>										
Location	2009	2010	2011	2012	2013	2014	2015	2016	2017	2018
<b>HARPER ROAD</b>	26,878	26,409	25,996	25,344	25,450	23,879	25,247	25,989	25,186	26,841
<b>HUNT</b>	8,288	7,539	8,914	8,933	8,716	8,642	8,286	8,603	9,554	10,208
<b>INGRAM</b>	15,092	14,859	13,125	11,837	11,815	10,393	10,648	11,198	10,980	14,778
<b>JACK FURMAN</b>	-	-	2,608	3,819	3,837	4,792	4,971	5,203	5,310	3,105
<b>RIM ROCK</b>	16,895	16,833	19,552	17,352	17,372	16,042	17,148	17,713	16,969	18,420
<b>TURTLE CREEK</b>	8,870	9,212	9,181	9,404	9,305	8,721	9,454	9,857	10,221	11,267
<b>SUBTOTAL</b>	76,023	74,852	79,376	76,689	76,495	72,469	75,754	78,563	78,220	84,619

**APPLICATION OF LCRA TRANSMISSION SERVICES CORPORATION  
TO AMEND ITS CERTIFICATE OF CONVENIENCE AND NECESSITY  
FOR THE PROPOSED MOUNTAIN HOME 138-KV TRANSMISSION LINE PROJECT IN  
GILLESPIE, KERR, AND KIMBLE COUNTIES, TEXAS**

**Table 14-4: Projected Winter Peak Loads at Harper and Doss<sup>2</sup>**

BUS NUMBER	SUBSTATION	2019-2020 kW	2020-2021 kW	2023-2024 kW	2026-2027 kW	2029-2030 kW
7410	Harper	16,329	16,843	18,496	20,329	22,362
7408	Doss	3,596	3,732	4,171	4,662	5,210
Total:		19,925	20,575	22,667	24,990	27,572

**Table 14-5: Projected Peak Electric Load with the Proposed Project.**

BUS NUMBER	SUBSTATION	2019-2020 kW	2020-2021 kW	2023-2024 kW	2026-2027 kW	2029-2030 kW
7410	Harper	16,329	9,303	10,955	11,320	12,501
7408	Doss	3,596	3,732	4,171	4,662	5,210
Subtotal:		19,925	13,035	15,126	15,982	17,711
7142	Ingram (CTEC)	6,712	5,153	5,853	6,648	7,551
7750	Mountain Home	0	8,366	9,192	10,106	11,122
Total:		26,637	26,554	30,171	32,736	36,384

Based on the need identified by CTEC for a new dually-served load serving substation in the Mountain Home area, LCRA TSC evaluated the ability of the existing transmission system to serve the new substation from two transmission sources. This evaluation was conducted in adherence with the requirements set forth in NERC Reliability Standards, ERCOT Nodal Protocols, ERCOT Planning Guides, and LCRA TSC’s Transmission Planning Criteria. The report containing the details of the steady state load flow analysis performed for this project and provided to the ERCOT Regional Planning Group is provided as Attachment 2.

The area load levels used to evaluate the existing transmission system performance were taken from the CTEC study and the ERCOT SSWG power flow cases.

**Table 14-6: Area winter transmission system loads served by the Gillespie and Fredericksburg Autotransformers**

BUS NUMBER	SUBSTATION	2020-2021 MW
7410	Harper	16.843
7408	Doss	3.732
Subtotal:		20.575
7412	Live Oak	10.226
7414	Goehmann Lane	12.815
7122	Eckert	2.323
7124	Nebo	4.141
Subtotal:		29.505
Total:		50.080

<sup>2</sup> Based on CTEC Distribution Study dated June 27, 2016 (Attachment 6).

**APPLICATION OF LCRA TRANSMISSION SERVICES CORPORATION  
TO AMEND ITS CERTIFICATE OF CONVENIENCE AND NECESSITY  
FOR THE PROPOSED MOUNTAIN HOME 138-KV TRANSMISSION LINE PROJECT IN  
GILLESPIE, KERR, AND KIMBLE COUNTIES, TEXAS**

---

LCRA TSC’s analysis of the existing transmission system determined that the existing 69-kV transmission serving the Harper and Doss substations will experience the thermal criteria violations reported in Table 14-7 based on the load levels forecasted to occur by winter of 2020/2021:

**Table 14-7: Transmission System Thermal Criteria Violations before the Proposed Project**

Monitored Element	Rate A (MVA)	Rate B (MVA)	NERC Contingency Category	Loading (% of Rate B)
Gillespie Auto	45	49	P1	109
Fredericksburg Auto	45	49	P1	103

The LCRA TSC analysis also shows voltage at the Harper and Doss substations is less than 0.9 per unit (a condition that violates the ERCOT and LCRA TSC steady state voltage criteria) based on projected Winter 2020/2021 load levels.

**Table 14-8: Transmission System Voltage Violations before the Proposed Project**

Bus	NERC Contingency Category	Voltage (Per Unit)
Doss Substation	P1	0.8883
Harper Substation	P1	0.8959

Thermal overloads on autotransformers result in degradation of the internal insulation and can result in catastrophic failure leading to extended outages for customers. Voltages of less than 0.9 per unit are a violation of ERCOT and LCRA TSC voltage performance criteria and result in an inability to maintain adequate voltage to customers resulting in possible damage to motors and other voltage sensitive devices.

Awareness of the poor voltage performance of the system and overloads of similar magnitude to those identified in the planning studies led ERCOT staff to approve a Mitigation Plan that calls for the shedding of load at Harper and Doss during high load levels. The Mitigation Plan was first approved on January 6, 2017 and was renewed in 2018 and again in 2019. Because the mitigation plan interrupts service to consumers, it is a temporary operational measure to avoid unsafe operating conditions and protect transmission equipment until the Proposed Project is completed.

Although not a primary driver for the project, another condition identified in LCRA TSC’s analysis of the transmission system in the area of the Proposed Project is the vulnerability of load served by the 138-kV transmission lines serving the six substations located west of the City of Kerrville including the Hunt and Ingram substations. The vulnerability occurs when one of two transmission elements that source the lines is out of service leaving the entire load served by the loop vulnerable to the loss of the other

**APPLICATION OF LCRA TRANSMISSION SERVICES CORPORATION  
TO AMEND ITS CERTIFICATE OF CONVENIENCE AND NECESSITY  
FOR THE PROPOSED MOUNTAIN HOME 138-KV TRANSMISSION LINE PROJECT IN  
GILLESPIE, KERR, AND KIMBLE COUNTIES, TEXAS**

element. The 138-kV loop is 52 miles long and provides transmission service to the Harper Road, Jack Furman, Ingram, Hunt, Turtle Creek, and Rim Rock substations. These six substations serve a total of 100.6 MW according to the winter 2021 load. Table 14-9 summarizes the amount of load loss that can occur during various combinations of element outages.

**Table 14-9: Winter 2020-2021 P6 Contingency Load Loss**

Contingency 1	Contingency 2	Number of Stations	Load (MW)
		7138 L_KERRST8_1Y138.00 7140 L_HARPRO8_1Y138.00 1	7146 L_VERDCR8_1Y138.00 7442 L_TURTCR8_1Y138.00 1
7140 L_HARPRO8_1Y138.00 7141 L_JACKFU8_1Y138.00 1	7146 L_VERDCR8_1Y138.00 7442 L_TURTCR8_1Y138.00 1	5	71.4
7141 L_JACKFU8_1Y138.00 7142 L_INGRAM8_1Y138.00 1	7144 L_HUNT_8_1Y138.00 7442 L_TURTCR8_1Y138.00 1	2	29.6

In summary, LCRA TSC and CTEC identified four planning criteria violations in the existing system that require system improvement:

1. Distribution feeders that exceed the 6 MW load limit established by CTEC’s planning criteria.
2. Total load at the Harper and Doss substations, served by a radial transmission line, in excess of 20 MW, which exceeds the CTEC and LCRA TSC Transmission System Planning Criteria.
3. Overloads on autotransformers at the Gillespie and Fredericksburg substations.
4. Low voltage at the Harper and Doss substations.

The Proposed Project, in conjunction with the conversion of the existing 69-kV transmission line from the Live Oak Substation to the Harper Substation to 138-kV operation, provide the system improvements needed to resolve these four planning criteria violations and meet the long-term transmission system performance requirements for the area.

In addition, the Proposed Project provides a third source into the transmission system serving the area west of Kerrville. This third source, via a connection of the Proposed Project at either the Hunt Substation or the Ingram Substation, reduces the amount of load loss at risk during maintenance outages on the 138-kV transmission system serving the area west of the City of Kerrville.

**APPLICATION OF LCRA TRANSMISSION SERVICES CORPORATION  
TO AMEND ITS CERTIFICATE OF CONVENIENCE AND NECESSITY  
FOR THE PROPOSED MOUNTAIN HOME 138-KV TRANSMISSION LINE PROJECT IN  
GILLESPIE, KERR, AND KIMBLE COUNTIES, TEXAS**

---

**For interconnection projects, provide any documentation from a transmission service customer, generator, transmission service provider, or other entity to establish that the proposed facilities are needed.**

Attachment 6 contains the CTEC Harper Substation Distribution Alternative Study dated June 27, 2016.

**For projects related to a Competitive Renewable Energy Zone, the foregoing requirements are not necessary; the applicant need only provide a specific reference to the pertinent portion(s) of an appropriate commission order specifying that the facilities are needed.**

The Proposed Project is not related to CREZ.

**For all projects, provide any documentation of the review and recommendation of a PURA §39.151 organization.**

LCRA TSC submitted the Proposed Project (including alternatives that terminate at Wolf Creek, which is described in the response to Question 15 of this Application) for review by ERCOT staff and the ERCOT RPG on November 18, 2016. All comments submitted in the ERCOT RPG process regarding the Proposed Project support the project. Following its review, ERCOT staff determined that the Proposed Project will not result in any violations of NERC or ERCOT's performance requirements and designated the Proposed Project as a Tier 4 Neutral Project on September 14, 2017. The documentation associated with ERCOT's review and determination is provided as Attachment 2 to this Application.

**15. Alternatives to Project:**

**For a standard application, describe alternatives to the construction of this project (not routing options). Include an analysis of distribution alternatives, upgrading voltage or bundling of conductors of existing facilities, adding transformers, and for utilities that have not unbundled, distributed generation as alternatives to the project. Explain how the project overcomes the insufficiencies of the other options that were considered.**

**Alternatives to the construction of this project (not routing options)**

CTEC and LCRA TSC considered and evaluated distribution alternatives and more than 34 transmission alternatives to constructing the Proposed Project. The feasibility of each alternative was analyzed according to the following parameters:

1. Reduce individual distribution feeder loading to less than 6 MW.
2. Result in the interruption of no more than 20 MW of load following a single transmission system contingency.

**APPLICATION OF LCRA TRANSMISSION SERVICES CORPORATION  
TO AMEND ITS CERTIFICATE OF CONVENIENCE AND NECESSITY  
FOR THE PROPOSED MOUNTAIN HOME 138-KV TRANSMISSION LINE PROJECT IN  
GILLESPIE, KERR, AND KIMBLE COUNTIES, TEXAS**

---

3. Provide adequate voltage support at the transmission bus which is defined as 0.95 per unit under system normal conditions and 0.92 per unit following a single contingency.
4. Not result in any transmission system overloads following contingencies in accordance with the NERC Transmission Planning Standards and ERCOT Transmission Guides.
5. Provide sufficient capacity to meet the long-term demand for electricity in the area.

**Distribution Alternatives**

Distribution alternatives that relieve feeder loading and reduce the combined load served by the Harper and Doss substations to less than 20 MW are limited due to the location of forecasted load growth relative to existing transmission sources and the distance to nearby distribution feeders (see Attachment 6). Figure 15-1 provides a diagram of the relative location of transmission sources to the area of anticipated growth. Further complicating the possible alternative distribution solutions is the differing operating voltages of the distribution systems at Harper and Wolf Creek (24-kV) and Ingram (12-kV), which makes transferring load between the substations more costly and requires interruptions to service to facilitate the change in voltage.

Other than the current transmission source out of the radially-served 69-kV Harper Substation, the concentration of existing and forecasted load growth in the Mountain Home area is over seven miles from the next nearest transmission sources, which are the Ingram Substation and the Hunt Substation. The next closest transmission substation is Jack Furman Substation (over nine miles). The existing CTEC distribution feeders extending toward the Mountain Home area of forecasted load growth are either from the north (Harper Substation), the southeast (Ingram and Jack Furman), or east (Wolf Creek). The nearest transmission source without existing CTEC distribution feeders is the Hunt Substation (approximately seven miles to the south). The nearest transmission source west of the area is Segovia Substation (more than 25 miles) and Atlantic Substation (more than 44 miles) and would require construction of 50 percent or more of the distribution feeder length outside of CTEC's certificated service territory. Furthermore, these sources from the west are all 69-kV sources with limited capacity (see discussion of transmission alternatives below).

Based on the proximity of existing distribution feeders and potential existing transmission sources, CTEC developed and evaluated a distribution alternative to the Proposed Project that requires construction of the following distribution facilities:

1. A new 25-kV circuit (Circuit 3-4) from Harper Substation to reduce load on Circuit 3-1 and provide capacity to transfer load from Feeder 3-2.
2. A new 25-kV tie line to move load from Circuit 3-2 to Circuit 3-1.
3. A new distribution tie line to move load from Circuit 3-2 to Circuit 3-4.
4. A new 25-kV circuit (Circuit 3-5).

**APPLICATION OF LCRA TRANSMISSION SERVICES CORPORATION  
TO AMEND ITS CERTIFICATE OF CONVENIENCE AND NECESSITY  
FOR THE PROPOSED MOUNTAIN HOME 138-KV TRANSMISSION LINE PROJECT IN  
GILLESPIE, KERR, AND KIMBLE COUNTIES, TEXAS**

5. A distribution step down transformer to transfer load from Ingram Circuit 4-2 to Wolf Creek Circuit 19-3.
6. A 25-kV line and rebuild of 7.6 miles of single phase distribution to three phase distribution to move load from Circuit 3-2 to Ingram Circuit 4-2.

This distribution alternative shifts 2,828 kW from Circuit 3-2 and achieves a net reduction of the load served by the Harper Substation by 1,918 kW. Based on the load forecast, this solution reduces the total load at Harper and Doss substations served by the existing radial 69-kV transmission line to less than 20 MW for only two years. This alternative also does not shift enough load to receive adequate voltage support from the existing transmission system (see discussion of voltage support in the response to Question 14).

The distance to other area substations with enough transmission capacity (e.g., Hunt Substation) to support additional load growth are too far from the Mountain Home area (over seven miles) to reliably and cost effectively connect new distribution feeders with the ability to provide long-term distribution solutions. Therefore, solutions that provided transmission service to a new substation located in the Mountain Home area were evaluated.

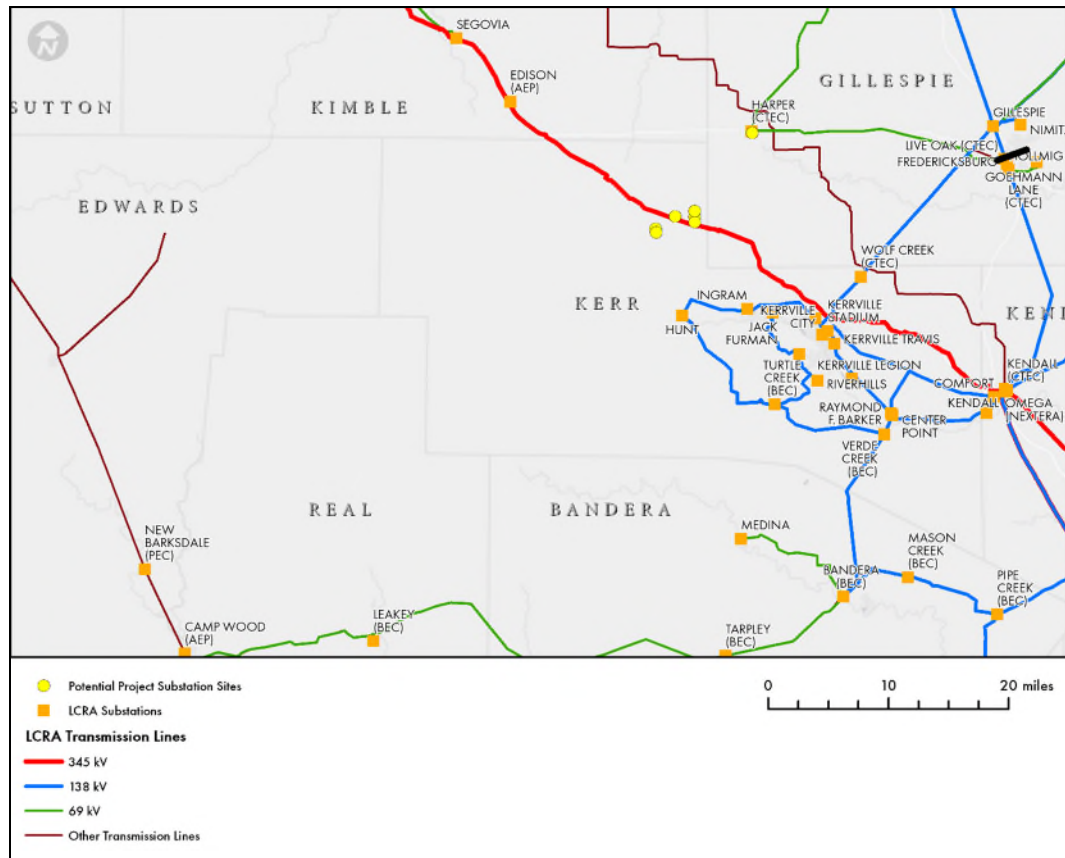

**Figure 15-1: Location of Potential Substation and the existing transmission system**



**APPLICATION OF LCRA TRANSMISSION SERVICES CORPORATION  
TO AMEND ITS CERTIFICATE OF CONVENIENCE AND NECESSITY  
FOR THE PROPOSED MOUNTAIN HOME 138-KV TRANSMISSION LINE PROJECT IN  
GILLESPIE, KERR, AND KIMBLE COUNTIES, TEXAS**

---

**Transmission Alternatives**

As a result of limited reasonable, long-term distribution-only system alternatives to address the system reliability issues in the Mountain Home area, LCRA TSC evaluated more than 34 transmission alternatives for connecting a new Mountain Home Substation to the existing electric system based on their ability to provide long-term solutions to the four planning criteria violations identified in the response to Question 14. The alternatives included possible transmission connections to the new Mountain Home Substation from existing substations at Atlantic, Harper, Hunt, Ingram, Medina City, Segovia, and Wolf Creek, and a possible new substation located between Hunt and Ingram. Jack Furman was not considered as a viable endpoint for the project because it is further from the Mountain Home load area than Harper or Ingram and has limited room for expansion. Also among the alternatives evaluated were 345-kV connections to the existing series-compensated Big Hill – Kendall 345-kV transmission line that is located close to the proposed sites for the new Mountain Home Substation.

**Table 15-1: List of Conceptual Alternatives Considered**

<b>Alternative</b>	<b>Description</b>
1	Add 138-kV circuit from Hunt to Mountain Home to Harper and install 138/69-kV autotransformer at Harper
2	Add 138-kV circuit from Hunt to Mountain Home to Harper, install 138/69-kV autotransformer at Harper, upgrade Harper to Live Oak to Gillespie to 138-kV
3	Add 138-kV circuit from Hunt to Mountain Home to Harper, install 138/69-kV autotransformer at Harper, upgrade Harper to Live Oak to Fredericksburg to 138-kV
4	Add 138-kV circuit from Hunt to Mountain Home to Harper, install 138/69-kV autotransformer at Harper, upgrade Harper to Live Oak to Hollmig to 138-kV
5	Add 138-kV circuit from Hunt to Mountain Home to Harper, install 138/69-kV autotransformer at Harper, upgrade Harper to Live Oak to 138-kV and cut into T379
6	Add 138-kV circuit from Ingram to Mountain Home to Harper and install 138/69-kV autotransformer at Harper
7	Add 138-kV circuit from Ingram to Mountain Home to Harper, install 138/69-kV autotransformer at Harper, upgrade Harper to Live Oak to Gillespie to 138-kV
8	Add 138-kV circuit from Ingram to Mountain Home to Harper, install 138/69-kV autotransformer at Harper, upgrade Harper to Live Oak to Fredericksburg to 138-kV
9	Add 138-kV circuit from Ingram to Mountain Home to Harper, install 138/69-kV autotransformer at Harper, upgrade Harper to Live Oak to Hollmig to 138-kV
10	Add 138-kV circuit from Ingram to Mountain Home to Harper, install 138/69-kV autotransformer at Harper, upgrade Harper to Live Oak to 138-kV and cut into T379

**APPLICATION OF LCRA TRANSMISSION SERVICES CORPORATION  
TO AMEND ITS CERTIFICATE OF CONVENIENCE AND NECESSITY  
FOR THE PROPOSED MOUNTAIN HOME 138-KV TRANSMISSION LINE PROJECT IN  
GILLESPIE, KERR, AND KIMBLE COUNTIES, TEXAS**

<b>Alternative</b>	<b>Description</b>
11	Add 138-kV circuit from New Substation between Hunt & Ingram to Mountain Home to Harper and install 138/69-kV autotransformer at Harper
12	Add 138-kV circuit from New Substation between Hunt & Ingram to Mountain Home to Harper, install 138/69-kV autotransformer at Harper, upgrade Harper to Live Oak to Gillespie to 138-kV
13	Add 138-kV circuit from New Substation between Hunt & Ingram to Mountain Home to Harper, install 138/69-kV autotransformer at Harper, upgrade Harper to Live Oak to Fredericksburg to 138-kV
14	Add 138-kV circuit from New Substation between Hunt & Ingram to Mountain Home to Harper, install 138/69-kV autotransformer at Harper, upgrade Harper to Live Oak to Hollmig to 138-kV
15	Add 138-kV circuit from New Substation between Hunt & Ingram to Mountain Home to Harper, install 138/69-kV autotransformer at Harper, upgrade Harper to Live Oak to 138-kV and cut into T379
16	Add 138-kV circuit from Hunt to Mountain Home, add 138-kV circuit from Doss to T214, install 138/69-kV autotransformer at Doss
17	Add 138-kV circuit from Ingram to Mountain Home, add 138-kV circuit from Doss to T214, install 138/69-kV autotransformer at Doss
18	Add 138-kV circuit from New Substation between Hunt & Ingram to Mountain Home, add 138-kV circuit from Doss to T214, install 138/69-kV autotransformer at Doss
19	Add 138-kV circuit from Wolf Creek to Mountain Home to Harper and install 138/69-kV autotransformer at Harper
20	Add 138-kV circuit from Wolf Creek to Mountain Home to Hunt, add 138-kV circuit from Doss to T214, install 138/69-kV autotransformer at Doss
21	Add 69-kV (138-kV capable) circuit from Segovia to Mountain Home to Harper
22	Add 345/138 kV autotransformers into the Big Hill to Kendall 345-kV transmission line at Mountain Home, add 138-kV circuit from Mountain Home to Harper, install 138/69-kV autotransformer at Harper, upgrade Harper to Live Oak to Gillespie to 138-kV
23	Add 345/138 kV autotransformers into the Big Hill to Kendall 345-kV transmission line at Mountain Home, add 138-kV circuit from Mountain Home to Harper, install 138/69-kV autotransformer at Harper, upgrade Harper to Live Oak to Fredericksburg to 138-kV
24	Add 345/138 kV autotransformers into the Big Hill to Kendall 345-kV transmission line at Mountain Home, add 138-kV circuit from Mountain Home to Harper, install 138/69-kV autotransformer at Harper, upgrade Harper to Live Oak to Hollmig to 138-kV
25	Add 345/12 kV auto at Mountain Home on T558 or T559, add 138-kV circuit from Doss to T214, install 138/69-kV autotransformer at Doss
26	Add 345/12 kV auto at Mountain Home on T558 or T559, add 69-kV (138-kV capable) circuit from Doss to Mason Philips
27	Add 69-kV (138-kV capable) circuit from Atlantic to Mountain Home to Harper
28	Add 138-kV circuit from Hunt to Mountain Home, add 69-kV (138-kV capable) circuit from Doss to Mason Philips

**APPLICATION OF LCRA TRANSMISSION SERVICES CORPORATION  
TO AMEND ITS CERTIFICATE OF CONVENIENCE AND NECESSITY  
FOR THE PROPOSED MOUNTAIN HOME 138-KV TRANSMISSION LINE PROJECT IN  
GILLESPIE, KERR, AND KIMBLE COUNTIES, TEXAS**

<b>Alternative</b>	<b>Description</b>
29	Add 138-kV circuit from Ingram to Mountain Home, add 69-kV (138-kV capable) circuit from Doss to Mason Philips
30	Add 138-kV circuit from New Substation between Hunt & Ingram to Mountain Home, add 69-kV (138-kV capable) circuit from Doss to Mason Philips
31	Add 138-kV circuit from Medina City to Mountain Home to Harper, upgrade Medina City to Bandera to 138-kV, install 138/69-kV autotransformer at Harper, upgrade Harper to Live Oak to Gillespie to 138-kV
32	Add 138-kV circuit from Medina City to Mountain Home to Harper, upgrade Medina City to Bandera to 138-kV, install 138/69-kV autotransformer at Harper, upgrade Harper to Live Oak to Fredericksburg to 138-kV
33	Add 138-kV circuit from Medina City to Mountain Home to Harper, upgrade Medina City to Bandera to 138-kV, install 138/69-kV autotransformer at Harper, upgrade Harper to Live Oak to Hollmig to 138-kV
34	Add 138-kV circuit from Medina City to Mountain Home to Harper, upgrade Medina City to Bandera to 138-kV, install 138/69-kV autotransformer at Harper, upgrade Harper to Live Oak to 138-kV and cut into T379

The 34 alternatives listed above provide either 138-kV Dual Feed or 345-kV transmission sources to the proposed Mountain Home Substation. A set of radial transmission alternatives was also evaluated.

1. Radial Transmission Alternatives

Radial transmission alternatives from the existing Harper Substation to the new Mountain Home Substation do not reduce the amount of load served by a radial transmission feed to less than 20 MW and do not improve voltage performance at the Harper and Doss substations in the long-term. In addition, transmission service to the Harper Substation must also be upgraded to provide adequate voltage support.

Two options to upgrade transmission service to the Harper Substation and support a radial transmission line to a new Mountain Home Substation were evaluated: (1) add shunt capacitors at the existing Harper Substation, or (2) upgrade and convert the existing Live Oak to Harper transmission line (T288) to 138-kV operation.

The total amount of shunt capacitors that are needed at Harper is 31.2 MVAR in order to meet the 2024 winter peak load forecast. This amount of shunt compensation exceeds the amount that can be switched in a single step without excessive voltage swings. The rate of growth expected in the Mountain Home area combined with the inability of the 69-kV system to support voltage at the Harper and Doss substations renders the shunt capacitor option an ineffective solution.

The second option for addressing voltage support at Harper Substation is upgrading the existing 69-kV transmission line from Live Oak to Harper for 138-kV operation. An

**APPLICATION OF LCRA TRANSMISSION SERVICES CORPORATION  
TO AMEND ITS CERTIFICATE OF CONVENIENCE AND NECESSITY  
FOR THE PROPOSED MOUNTAIN HOME 138-KV TRANSMISSION LINE PROJECT IN  
GILLESPIE, KERR, AND KIMBLE COUNTIES, TEXAS**

---

outage to rebuild the Live Oak to Harper transmission line results in an outage to the entire community of Harper and all CTEC members served from the Harper and Doss substations. Without a second feed to the Harper Substation, rebuilding the existing Live Oak to Harper line for 138-kV operation requires a long-term outage, energized construction techniques, or construction on new right-of-way parallel to the existing transmission line. Thus, a new transmission source into either the Harper or Doss substation is necessary to avoid significant interruption to service from long-term outages that would occur during an extensive overhaul of the Live Oak to Harper transmission line to 138-kV operation (since that line is the only source to those two substations) (see Figure 15-1).

Hunt, Ingram, a new substation between Hunt and Ingram, or Wolf Creek substations (from the south and southeast of Mountain Home) all connect to a strong 138-kV transmission system. Radial transmission lines from these locations are capable of providing transmission service to the new Mountain Home Substation. However, these radial transmission alternatives do not provide long-term relief of the poor voltage performance at the Harper and Doss substations.

Other radial transmission alternatives considered and evaluated include a possible new transmission line to the Mountain Home Substation from Atlantic, Medina City, or Segovia substations. These substation end points connect to 69-kV transmission facilities with limited capacity to serve additional load. In addition, these substations are an approximate straight-line distance of 45 miles (Atlantic), 26 miles (Medina City), and 27 miles (Segovia), respectively, thus significantly increasing the amount of new transmission line that would need to be constructed.

LCRA TSC determined that radial transmission line options to serve a new Mountain Home substation are inadequate because they either do not meet the LCRA TSC and CTEC requirement limiting the interruption of load from a single contingency event to less than 20 MW, do not resolve the voltage support needs at Harper and Doss substations, require outages to existing radial circuits, or require the construction of a significantly longer new transmission line than the Proposed Project (see Table 15-2).

In consideration of the need to upgrade the existing Live Oak to Harper 69-kV transmission line and the need to avoid long-term outages to customers served from Harper and Doss substations, LCRA TSC evaluated alternatives that provided a new transmission source to Harper Substation and transmission service to the Mountain Home load area. These alternatives included revisiting a connection to Segovia to the west and Wolf Creek Substation to the east in addition to connections at Ingram and Hunt to the south. Options that connect to Ingram and Hunt are routing alternatives to the Proposed Project and are discussed in response to Question 14.

**APPLICATION OF LCRA TRANSMISSION SERVICES CORPORATION  
TO AMEND ITS CERTIFICATE OF CONVENIENCE AND NECESSITY  
FOR THE PROPOSED MOUNTAIN HOME 138-KV TRANSMISSION LINE PROJECT IN  
GILLESPIE, KERR, AND KIMBLE COUNTIES, TEXAS**

**Table 15-2: Summary of Performance of Radial Options to Serve Mountain Home**

Option	Straight-Line Distance from Mountain Home Load Center (Miles)	Solves Voltage Support Needs at Harper	Provides Voltage Support Needs at Mountain Home	Does Not Require upgrades to existing radial circuits	Reduces Harper/Doss load below 20 MW
Radial from Harper	8.4	No	No	No	No
Radial from Hunt	8.3	No	Yes	No	Short-term
Radial from Ingram	8.8	No	Yes	No	Short-term
Radial from Wolf Creek	14.7	No	Yes	No	Short-term
Radial from Atlantic	44	No	No	No	Short-term
Radial from Medina City	27	No	No	No	Short-term
Radial from Segovia	24.7	No	No	No	Short-term

2. Dual Feed Transmission Alternatives

a. Wolf Creek to Mountain Home to Harper

An alternative, referred to as Alternative 3 in LCRA TSC's RPG submittal, consisted of:

1. constructing a new Mountain Home Substation, adding one 138/69-kV autotransformer at the Harper Substation;
2. constructing a 138-kV transmission line from the Wolf Creek Substation to the Mountain Home Substation to the Harper Substation;
3. converting the existing 69-kV Harper to Live Oak transmission line (T288) to 138-kV;
4. converting the Live Oak substation to 138-kV;

**APPLICATION OF LCRA TRANSMISSION SERVICES CORPORATION  
TO AMEND ITS CERTIFICATE OF CONVENIENCE AND NECESSITY  
FOR THE PROPOSED MOUNTAIN HOME 138-KV TRANSMISSION LINE PROJECT IN  
GILLESPIE, KERR, AND KIMBLE COUNTIES, TEXAS**

---

5. cutting-in the existing Gillespie to Fredericksburg 138-kV transmission line (T379) at Live Oak; and
6. connecting the 69-kV Gillespie to Live Oak (T131) and Live Oak to Goehmann Tap (T287) transmission lines to create a continuous 69-kV circuit from the Gillespie to Goehmann Tap substations.

This alternative does not address the potential for more than 100 MW of load loss at the substations served by the Kerrville West Loop identified in response to Question 14 (see Table 14-2). The straight line distance from the Mountain Home load area to Wolf Creek is more than 14 miles. Based on costs used at the time of the RPG submittal, the estimated cost of this longer alternative is approximately \$20 million higher than the Proposed Project (from either Hunt or Ingram).

Wolf Creek Substation is served from a 138-kV transmission line from Kerrville Stadium to Gillespie Substation in Fredericksburg, a major transmission path for the reliability of service to the Fredericksburg area, of which Harper Substation is a part, and does not provide any diversification of transmission sources to the area served by Harper Substation or to the west Kerrville Loop transmission system.

b. Harper to Mountain Home to Segovia

LCRA TSC evaluated two options for serving the new Mountain Home Substation from Harper Substation and Segovia Substation. These options are:

- i. Harper to Mountain Home to Segovia Option 1 – Install a 138/69 kV autotransformer at Harper and construct a 69-kV transmission line from Harper to Mountain Home to Segovia. Install two (2) 3.9 MVAR capacitors at Harper Substation, two (2) 3.9 MVAR capacitors at Segovia Substation, and one (1) 3.9 MVAR capacitor at Mountain Home Substation.
- ii. Harper to Mountain Home to Segovia Option 2 – Construct a 138-kV transmission line from Harper to Mountain Home, install a 138/69 kV autotransformer at Mountain Home, and extend a 69-kV transmission line from Mountain Home to Segovia. Install two (2) 3.9 MVAR capacitors at Harper Substation, two (2) 3.9 MVAR capacitors at Segovia Substation, and one (1) 3.9 MVAR capacitor at Mountain Home Substation.

Segovia Substation receives transmission service from a single, 9.1 mile, 69-kV transmission line via a tap into a 69-kV transmission line between the Shell London Tap and the Kimble-Junction substations. The nearest 138-kV source to Segovia is 46.2 circuit miles away. The next closest 138-kV source is 66.68 miles away. Power flow

**APPLICATION OF LCRA TRANSMISSION SERVICES CORPORATION  
TO AMEND ITS CERTIFICATE OF CONVENIENCE AND NECESSITY  
FOR THE PROPOSED MOUNTAIN HOME 138-KV TRANSMISSION LINE PROJECT IN  
GILLESPIE, KERR, AND KIMBLE COUNTIES, TEXAS**

---

analysis, showed that even with added reactive support these alternatives are only capable of serving load levels that are forecasted for the 2024/2025 winter peak. The straight line distance from the Mountain Home load area to Segovia is approximately 25 miles. The estimated cost to construct this new line and upgrade the existing 69-kV system serving Segovia is significantly higher than the Proposed Project (from either Hunt or Ingram) as planning level cost estimates for the transmission line construction of these alternatives alone would exceed \$110 million.

3. 345-kV Interconnection Alternatives

LCRA TSC considered and evaluated alternatives that would provide transmission service to a new Mountain Home Substation from the Big Hill to Kendall series-compensated 345-kV transmission line. After evaluation, these alternatives were rejected because they risk reliability to the 345-kV system by introducing significant new complex elements into the system, require additional upgrades of other 138-kV facilities, and have potentially large unknown financial impacts and uncertain costs.

Specifically, alternatives that connect the Big Hill to Kendall 345-kV transmission line to the new Mountain Home Substation are not as reliable as the 138-kV solutions because they expose equipment to wide swings in voltage that require the addition of sophisticated dynamic reactive support equipment to mitigate. The addition of dynamic reactive equipment into the heavily loaded 345-kV transmission system would introduce additional complex operational components that have the potential for unstable control interactions with the series capacitors and generators connected to the 345-kV system. The addition of such equipment would result in an increased potential for component failures within the 345-kV system and thus reduce reliability and availability of stable power to generators and consumers served by the new Mountain Home Substation. Connecting the Mountain Home Substation to only one of the 345-kV circuits is fraught with the potential for complications in assessing and implementing measures to counteract the susceptibility of generators to series compensated transmission lines and is not considered a reasonable solution.

LCRA TSC considered alternatives (which include alternatives 22 through 26 in Table 15-1 listed above) and ultimately studied in detail the following three configurations:

1. Tie in the Big Hill to Kendall 345-kV transmission line to the new Mountain Home Substation. This alternative does not provide looped transmission service to the Harper Substation and is vulnerable to wide swings in voltage during faults on the 345-kV system. The estimated cost of this alternative is \$50 million.
2. Tie in the Big Hill to Kendall 345-kV transmission line to the new Mountain Home Substation and construct a new line to the Hunt Substation or the Ingram Substation. This alternative does not provide looped transmission service to the

**APPLICATION OF LCRA TRANSMISSION SERVICES CORPORATION  
TO AMEND ITS CERTIFICATE OF CONVENIENCE AND NECESSITY  
FOR THE PROPOSED MOUNTAIN HOME 138-KV TRANSMISSION LINE PROJECT IN  
GILLESPIE, KERR, AND KIMBLE COUNTIES, TEXAS**

---

Harper Substation and is vulnerable to wide swings in voltage during faults on the 345-kV system, and introduces additional overload conditions on the 138-kV system in the Kerrville area. Table 15-3 and Table 15-4 show the additional overloaded elements. The estimated cost of this alternative, including the cost to mitigate voltage swings and the additional overloads is \$109 million.

3. Tie in the Big Hill to Kendall 345-kV transmission line to the new Mountain Home Substation and construct a new line to the Harper Substation. This alternative is vulnerable to wide swings in voltage during faults on the 345-kV system, and introduces additional overload conditions on the 138-kV system in the Fredericksburg area. Table 15-3 and Table 15-4 show the additional overloaded elements. The estimate cost of this alternative, including the cost to mitigate voltage swings and the additional overloads is \$88 million.



**APPLICATION OF LCRA TRANSMISSION SERVICES CORPORATION  
TO AMEND ITS CERTIFICATE OF CONVENIENCE AND NECESSITY  
FOR THE PROPOSED MOUNTAIN HOME 138-KV TRANSMISSION LINE PROJECT IN  
GILLESPIE, KERR, AND KIMBLE COUNTIES, TEXAS**

Table 15-3 is a list of overloads that occur under N-1 conditions during summer peak load conditions. The power flow models used for this analysis do not model peak wind output in West Texas. The cost of 345-kV alternatives listed above includes the upgrades needed to relieve these overloads.

<b>Table 15-3: Overloads for 345-kV Alternatives that connect to Hunt or Harper under Summer Peak Load conditions in 2022</b>			
<b>Branch</b>	<b>Ratings</b>	<b>Alternatives</b>	
		345kV + 138kV MH to Hunt	345kV + 138kV MH to Harper
7140 L_HARPRO8_1Y138.00 7141 L_JACKFU8_1Y138.00 1	128	162.6	<95%
7141 L_JACKFU8_1Y138.00 7142 L_INGRAM8_1Y138.00 1	128	168	<95%
7142 L_INGRAM8_1Y138.00 7144 L_HUNT__8_1Y138.00 1	128	177.4	<95%
7144 L_HUNT__8_1Y138.00 7442 L_TURTCR8_1Y138.00 1	128	127.3	<95%
7144 L_HUNT__8_1Y138.00 7750 L_MOUNHO8_1Y138.00 1	223	179.9	<95%
7146 L_VERDCR8_1Y138.00 7442 L_TURTCR8_1Y138.00 1	128	106.4	<95%
7412 L_LIVEOA9_1Y138.00 74100 L_HARPER8_1Y138.00 1	220	<95%	114.4
7750 L_MOUNHO8_1Y138.00 74100 L_HARPER8_1Y138.00 1	223	<95%	118.1

Table 15-4 provides a list of overloads that occur under N-1 conditions during summer peak load conditions. The power flow models used for this analysis do not model peak wind output in West Texas. Constraining the output in West Texas can relieve these overloads, however, the impact to the market is significant. For example, the ERCOT system experienced \$13.8 million<sup>3</sup> in congestion rent in January and February 2019 in which power flow from West Texas to Central Texas was forced onto the 138-kV system. The overloads reported in Table 15-4 are an indication that connecting the Big Hill to

<sup>3</sup> February 2019 ERCOT Monthly Operations Report to the Reliability and Operations Subcommittee [http://ercot.com/content/wcm/key\\_documents\\_lists/165182/Feb\\_19\\_ERCOT\\_Operations\\_Report\\_Public.docx](http://ercot.com/content/wcm/key_documents_lists/165182/Feb_19_ERCOT_Operations_Report_Public.docx)

**APPLICATION OF LCRA TRANSMISSION SERVICES CORPORATION  
TO AMEND ITS CERTIFICATE OF CONVENIENCE AND NECESSITY  
FOR THE PROPOSED MOUNTAIN HOME 138-KV TRANSMISSION LINE PROJECT IN  
GILLESPIE, KERR, AND KIMBLE COUNTIES, TEXAS**

Kendall 345-kV transmission line to the 138-kV system through the Mountain Home Substation would result in this type of congestion as well. In addition, developers of utility scale solar generation have requested interconnections representing 30,000 MW of capacity in West Texas that is not represented in the models used to present the results in Table 15-3 and Table 15-4.

<b>Table 15-4: Overloads for 345-kV Alternatives that connect to Hunt or Harper under high wind low load conditions in 2021</b>			
<b>Branch</b>	<b>Ratings</b>	<b>Alternatives</b>	
		345kV + 138kV MH to Hunt	345kV + 138kV MH to Harper
7140 L_HARPRO8_1Y138.00 7141 L_JACKFU8_1Y138.00 1	128	226.3	<95%
7141 L_JACKFU8_1Y138.00 7142 L_INGRAM8_1Y138.00 1	128	226.2	<95%
7142 L_INGRAM8_1Y138.00 7144 L_HUNT_8_1Y138.00 1	128	232.7	<95%
7144 L_HUNT_8_1Y138.00 7442 L_TURTCR8_1Y138.00 1	128	172	<95%
7144 L_HUNT_8_1Y138.00 7750 L_MOUNHO8_1Y138.00 1	223	235.7	<95%
7146 L_VERDCR8_1Y138.00 7442 L_TURTCR8_1Y138.00 1	128	158.6	<95%
7412 L_LIVEOA9_1Y138.00 7132 L_GILLES8_1Y138.00	221	<95%	102.5
7412 L_LIVEOA9_1Y138.00 74100 L_HARPER8_1Y138.00 1	220	<95%	152.3
7750 L_MOUNHO8_1Y138.00 74100 L_HARPER8_1Y138.00 1	223	<95%	152.9

Historical levels of congestion and the results presented in Tables 15-3 and 15-4, demonstrate that the Big Hill to Kendall 345-kV transmission line is a critical 345-kV corridor for transferring significant power (including wind and solar) from West Texas to Central Texas. In order to maximize its effectiveness, the Big Hill to Kendall transmission line is equipped with series capacitors that boost voltage to economically transfer low cost power over a long distance and make it ill-suited for reliably and economically connecting directly to a load-serving substation like the proposed Mountain Home Substation. Another factor affecting the connection of the Big Hill to Kendall 345-

**APPLICATION OF LCRA TRANSMISSION SERVICES CORPORATION  
TO AMEND ITS CERTIFICATE OF CONVENIENCE AND NECESSITY  
FOR THE PROPOSED MOUNTAIN HOME 138-KV TRANSMISSION LINE PROJECT IN  
GILLESPIE, KERR, AND KIMBLE COUNTIES, TEXAS**

---

kV transmission corridor at Mountain Home is the anticipated rapid growth in wind and solar power plants in West Texas. The April 2019 ERCOT Generation Interconnection Report lists over 35 GW of wind and solar generating capacity under study in the West Texas zone. As this generation comes online, additional transmission capacity will be required to deliver the power to load centers in Central and South Texas. Thus, interconnection of the new Mountain Home Substation to the Big Hill to Kendall 345-kV transmission line would decrease the reliability and operational efficiency of the West to South bulk power transfers precisely at a time when the need for reliability and capacity are increasing. After evaluation, LCRA TSC determined that connection of a load serving substation in the Big Hill to Kendall series-compensated 345-kV transmission line will not provide reliable service to the customers served from that substation, will diminish the effectiveness of the existing 345-kV system, will still require additional 138-kV transmission lines to loop Harper in the future, and potentially require new 345-kV transmission line infrastructure from Mountain Home in order to relieve congestion. Importantly, LCRA TSC's estimated cost of a direct connection of the new Mountain Home Substation to the series-compensated 345-kV transmission line and dual feed service to Harper Substation will significantly exceed the estimated cost of the Proposed Project and cannot be expected to avoid the need for further transmission line additions in the future.

**Analysis of (for utilities that have not unbundled), distributed generation as alternatives to the project.**

LCRA TSC is subject to the unbundling requirements of PURA § 39.051. Regardless, the defined need for the Proposed Project requires grid-scale solutions that provide large amounts of electric power to adequately serve existing and developing end-use customers over a broad area as well as to efficiently provide sufficient capacity for emergency support during emergency restoration efforts over an even wider area. Distributed Generation (DG) is not a viable option in this instance because it cannot be readily sited, controlled, or dispatched with an adequate level of certainty. DG alternatives do not provide a new transmission source to the current radially-fed Harper and Doss substations. A DG alternative does not avoid the need to construct a new Mountain Home substation. Solar DG, in particular, is not effective for meeting the winter system peak loads.

**Explain how the project overcomes the insufficiencies of the other options that were considered.**

The insufficiencies of the alternatives overcome by the Proposed Project include:

1. Distribution-only alternatives provide only short-term (two years) relief before transmission upgrades are required.

**APPLICATION OF LCRA TRANSMISSION SERVICES CORPORATION  
TO AMEND ITS CERTIFICATE OF CONVENIENCE AND NECESSITY  
FOR THE PROPOSED MOUNTAIN HOME 138-KV TRANSMISSION LINE PROJECT IN  
GILLESPIE, KERR, AND KIMBLE COUNTIES, TEXAS**

---

2. Radial transmission alternatives that extend the existing transmission line serving Harper leave 4,692 consumers representing more than 20 MW vulnerable to service interruptions from a single transmission element.
3. Transmission alternatives that extend transmission to existing 69-kV sources in the area such as Segovia do not provide adequate voltage support and result in overloads that are significantly more expensive to remedy than the Proposed Project.
4. Connections to the 345-kV Big Hill to Kendall transmission line that connect to the 138-kV system (Harper, Ingram, or Hunt substations) are more costly than the Proposed Project, introduces the risk of control interactions with existing generation, and introduce new elements that will result in constraining the development of low-cost generation located in West Texas.
5. Connecting a load serving substation to the 345-kV Big Hill to Kendall transmission line without connecting to the existing Harper, Ingram or Hunt substations introduces the risk of control interactions with existing generation and does not avoid the long-term need for new transmission lines to provide two-way service to Harper Substation.

In addition, the Proposed Project meets all of the following planning requirements:

1. Reduce individual distribution feeder loading to less than 6 MW.
2. Result in the interruption of no more than 20 MW of load following a single transmission system contingency.
3. Provide adequate voltage support at the transmission bus, which is defined as 0.95 per unit under system normal conditions, and 0.92 per unit following a single contingency.
4. Not result in any transmission system overloads following contingencies in accordance with the NERC Transmission Planning Standards and ERCOT Transmission Guides.
5. Provide sufficient capacity to meet the long-term demand for electricity in the area.

The Proposed Project also provides a geographically diverse transmission source to the western Kerrville area and to the Fredericksburg area at a lower cost than the Harper to Mountain Home to Wolf Creek alternative.

**APPLICATION OF LCRA TRANSMISSION SERVICES CORPORATION  
TO AMEND ITS CERTIFICATE OF CONVENIENCE AND NECESSITY  
FOR THE PROPOSED MOUNTAIN HOME 138-KV TRANSMISSION LINE PROJECT IN  
GILLESPIE, KERR, AND KIMBLE COUNTIES, TEXAS**

**16. Schematic or Diagram:**

For a standard application, provide a schematic or diagram of the applicant's transmission system in the proximate area of the project. Show the location and voltage of existing transmission lines and substations, and the location of the construction. Locate any taps, ties, meter points, or other facilities involving other utilities on the system schematic.

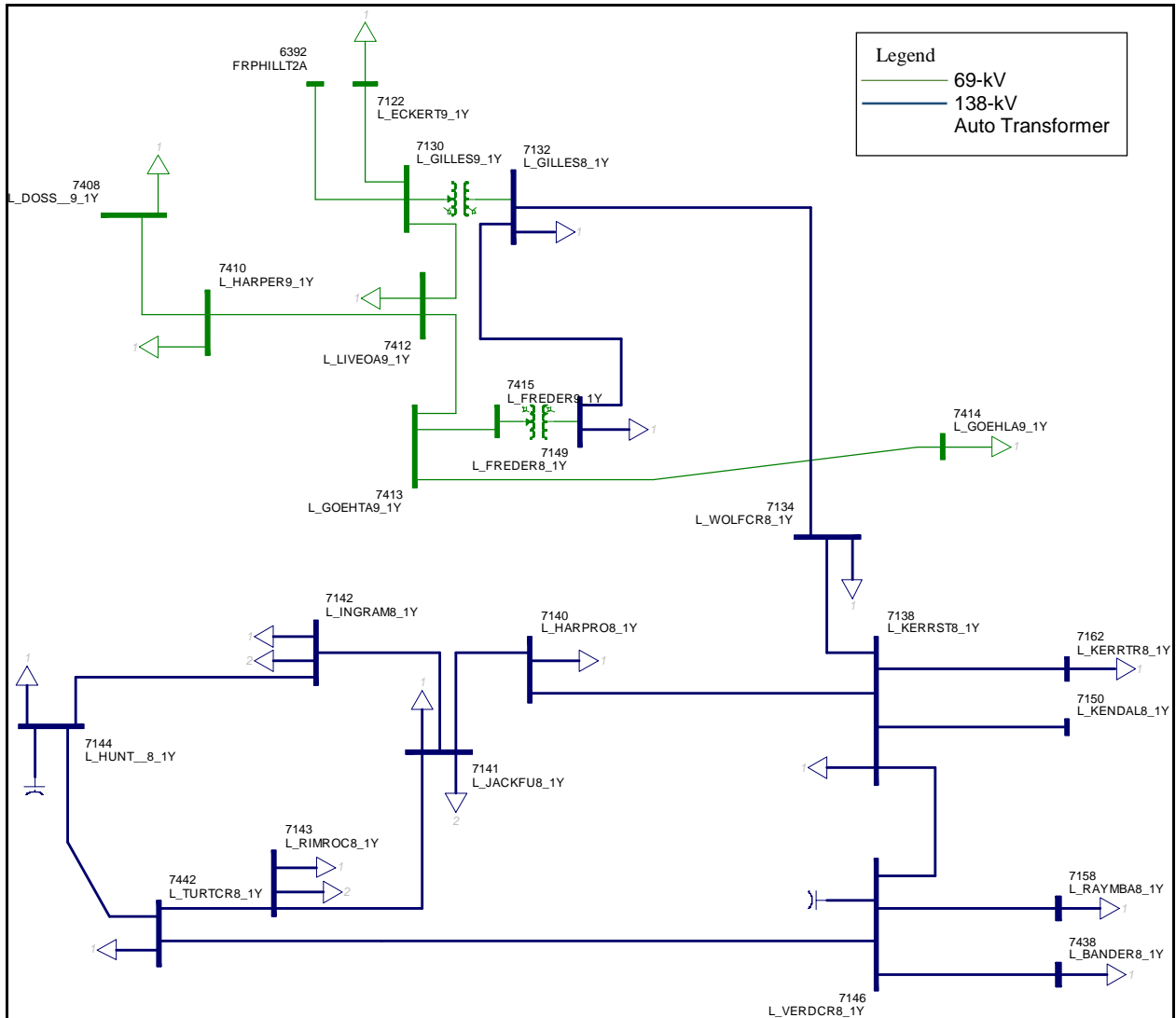

**Figure 16-1: One-line diagram of the existing transmission system**

A map of the transmission system in the vicinity of the project is provided as Attachment 7 to the Application.

**APPLICATION OF LCRA TRANSMISSION SERVICES CORPORATION  
TO AMEND ITS CERTIFICATE OF CONVENIENCE AND NECESSITY  
FOR THE PROPOSED MOUNTAIN HOME 138-KV TRANSMISSION LINE PROJECT IN  
GILLESPIE, KERR, AND KIMBLE COUNTIES, TEXAS**

---

**17. Routing Study:**

**Provide a brief summary of the routing study that includes a description of the process of selecting the study area, identifying routing constraints, selecting potential line segments, and the selection of the routes. Provide a copy of the complete routing study conducted by the utility or consultant. State which route the applicant believes best addresses the requirements of PURA and P.U.C. Substantive Rules.**

LCRA TSC retained POWER Engineers, Inc. (POWER) to prepare the EA, included as Attachment 1 to the Application. The objective of the EA was to provide information in support of this Application in addressing the requirements of Public Utility Regulatory Act (PURA)<sup>4</sup> § 37.056(c)(4)(A)-(D), the PUC CCN Application form, and PUC Substantive Rule 25.101 (16 TAC § 25.101). By examining existing environmental conditions, including the human and natural resources that are located in the area of the Proposed Project, the EA evaluates the environmental effects that could result from the construction, operation, and maintenance of the Proposed Project. The EA will also be used in support of any additional local, state, or federal permitting activities that may be required for the Proposed Project.

To assist POWER in its evaluation, LCRA TSC provided information regarding the project endpoints, the need for the project, engineering and design requirements, construction practices, and ROW requirements for the Proposed Project.

**Selecting the Study Area**

POWER, with input and assistance from LCRA TSC, delineated the study area within which to review the existing environment and eventually to locate geographically diverse alternative routes. The boundaries of the study area were determined by the existing project endpoints (the Harper, Hunt, and Ingram substations), the Mountain Home Substation siting area, other existing ROW (e.g., roadways and existing transmission lines), and existing cultural and land use features across the study area.

The final study area, shown in Figure 2-2 of the EA, is approximately 11 miles long by 16 miles wide, and encompasses an area of approximately 157 square miles (100,480 acres).

**Routing Constraints**

Once the study area was defined, data related to land use, aesthetics, ecology, and cultural resources were collected by POWER through: conducting ground reconnaissance; reviewing available maps and aerial photography; reviewing previous studies conducted

---

<sup>4</sup> Public Utility Regulatory Act, Tex. Util. Code §§ 11.001-66.016.

**APPLICATION OF LCRA TRANSMISSION SERVICES CORPORATION  
TO AMEND ITS CERTIFICATE OF CONVENIENCE AND NECESSITY  
FOR THE PROPOSED MOUNTAIN HOME 138-KV TRANSMISSION LINE PROJECT IN  
GILLESPIE, KERR, AND KIMBLE COUNTIES, TEXAS**

---

in the area; contacting a variety of local, state, and federal agencies; and considering criteria established in PURA § 37.056(c)(4)(A)-(D), the PUC's CCN Application form, PUC Substantive Rule 25.101, and input from the public open house meetings. Using this information, the locations of sensitive features and other constraints were identified.

**Selection of Potential Routing Segments**

Preliminary alternative route segments were identified by evaluation of the constraints mapped for the study area and then by identifying routing opportunity areas such as existing corridors and other linear features. Through application of the PUC's routing criteria, as described above, 119 preliminary alternative route segments were identified and developed into potentially viable preliminary alternative routes for comparative purposes. These preliminary alternative route segments were further evaluated based on information received from government agencies, the public meetings, and additional public input. Ultimately, 40 primary alternative routes were identified for comparison (30 originating out of the Hunt Substation and ten originating out of the Ingram Substation). These routes were evaluated using 44 land use and environmental criteria. Impacts were evaluated by POWER for each identified primary alternative route. Additional forward progressing alternative routes may also be formed by configuring the various segments proposed in this Application in different ways.

Specific discussion regarding selection of the study area, identification of constraints, the selection of potential preliminary alternative route segments, and the alternative route analysis is set forth in the EA in Sections 2.0, 3.0, 4.0, and 5.0.

**Selection of the alternative route the applicant believes best addresses the requirements of PURA and P.U.C. Substantive Rules**

LCRA TSC identified Route 13 as the primary alternative route that it believes best addresses the requirements of PURA and the PUC Substantive Rules. LCRA TSC's response is informed by a number of considerations (listed below in no particular order), including that Route 13:

- Has the third shortest length of the 40 primary alternative routes included in the Application (approximately 22.34 miles) and is only 0.86 mile longer than the shortest route;
- Has a relatively low number of habitable structures located within 300 feet of the route centerline (32) and 16 of the 32 habitable structures within 300 feet of Route 13 are currently located within 300 feet of the centerline of an existing 138-kV electric transmission line);

**APPLICATION OF LCRA TRANSMISSION SERVICES CORPORATION  
TO AMEND ITS CERTIFICATE OF CONVENIENCE AND NECESSITY  
FOR THE PROPOSED MOUNTAIN HOME 138-KV TRANSMISSION LINE PROJECT IN  
GILLESPIE, KERR, AND KIMBLE COUNTIES, TEXAS**

---

- Uses existing transmission line ROW (1.91 miles) or parallels and is adjacent to existing corridors (public roads/highways and apparent property lines) for approximately 79 percent of its total estimated length (17.56 of 22.34 miles);
- Has the seventh lowest estimated cost (\$63,995,000) of the 40 primary alternative routes included in the Application and is only approximately three percent more expensive than the least expensive route;
- Has the third lowest estimated length of ROW within the foreground visual zone of IH, US, and State Highways (approximately 2.92 miles);
- Does not cross any recorded cultural resources sites and has only one additional recorded cultural resources site located within 1,000 feet of the route centerline;
- Has the third shortest length of ROW across areas of high archeological/historic site potential (approximately 10.7 miles).

Apart from identifying Route 13 as the route that best addresses PURA and the PUC Substantive Rules for the purpose of completing this portion of the Application, LCRA TSC did not rank the other alternative routes.

**18. Public Meeting or Public Open House:**

**Provide the date and location for each public meeting or public open house that was held in accordance with 16 TAC § 22.52. Provide a summary of each public meeting or public open house including the approximate number of attendants, and a copy of any survey provided to attendants and a summary of the responses received. For each public meeting or public open house provide a description of the method of notice, a copy of any notices, and the number of notices that were mailed and/or published.**

LCRA TSC held two open house meetings for the Proposed Project. The first open house meeting was held on June 26, 2018, from 5:30 p.m. to 8:00 p.m. at the Mountain Home Volunteer Fire Department in Mountain Home, Texas. LCRA TSC mailed written notices of the meeting to all owners of property within approximately 300 feet of each preliminary alternative route segment centerline. Additional letters were sent to elected officials, the Department of Defense Siting Clearinghouse, and other interested parties. In total, LCRA TSC mailed 765 meeting notices for the Mountain Home open house. In addition, a public notice was published on the listed dates in the following four newspapers having circulation within the project area counties:

- *Fredericksburg Standard-Radio Post* - June 13 & June 20, 2018
- *Kerrville Daily Times* – June 13 & June 20, 2018
- *West Kerr Current* – June 14 & June 21, 2018
- *Junction Eagle* – June 13 & June 20, 2018



**APPLICATION OF LCRA TRANSMISSION SERVICES CORPORATION  
TO AMEND ITS CERTIFICATE OF CONVENIENCE AND NECESSITY  
FOR THE PROPOSED MOUNTAIN HOME 138-KV TRANSMISSION LINE PROJECT IN  
GILLESPIE, KERR, AND KIMBLE COUNTIES, TEXAS**

---

The second open house meeting was held on November 7, 2018, from 6:00 p.m. to 8:30 p.m. at Ingram Tom Moore High School in Ingram, Texas. LCRA TSC mailed written notices of the meeting to all owners of property within approximately 300 feet of each preliminary alternative route segment centerline that was added after the June 2018 Mountain Home open house. Additional letters were sent to elected officials, the Department of Defense Siting Clearinghouse, and other interested parties. In total, LCRA TSC mailed 367 meeting notices for the Ingram open house. In addition, a public notice was published on the listed dates in the following three newspapers having circulation within the project area counties:

- *Fredericksburg Standard-Radio Post* – October 31, 2018
- *Kerrville Daily Times* – October 31, 2018
- *West Kerr Current* – November 1, 2018

The public notices announced the location, time, and purpose of the meetings. A copy of the published newspaper notices are located in Appendix B of the EA.

Both meetings were intended to solicit comments from interested persons and public officials concerning the Proposed Project. The meetings had the following objectives:

- Promote a better understanding of the Proposed Project, including the purpose, need, potential benefits and impacts, and PUC certification process;
- Inform the public with regard to the routing procedure, schedule, and route approval process; and
- Gather the values and concerns of the public and community leaders.

The meetings were configured in an informal information station format rather than a formal speaker/audience format, with each station assigned to a particular aspect of the project or routing process and staffed with LCRA TSC or POWER personnel. These stations included maps, illustrations, photographs, and text explaining each topic. In addition, LCRA TSC and POWER provided GIS computer stations to show the extent of the project, the proposed preliminary alternative route segments, Gillespie, Kerr, and Kimble County Appraisal District parcel boundaries, and recent aerial photography of the project area. GIS-trained staff members were also available to answer detailed questions, such as the approximate distance from a proposed preliminary route segment centerline to the nearest corner of a habitable structure or other features of interest to the public. Attendees were encouraged to visit each station so that the entire process could be explained in the logical sequence of project development. The information station format is typically advantageous because it allows attendees to process information in a more relaxed manner, to focus on their particular area of interest, and to ask specific questions. Furthermore, the one-to-one discussions with LCRA TSC or POWER personnel typically

**APPLICATION OF LCRA TRANSMISSION SERVICES CORPORATION  
TO AMEND ITS CERTIFICATE OF CONVENIENCE AND NECESSITY  
FOR THE PROPOSED MOUNTAIN HOME 138-KV TRANSMISSION LINE PROJECT IN  
GILLESPIE, KERR, AND KIMBLE COUNTIES, TEXAS**

---

encourage more interaction from those attendees who might be hesitant to participate in a more formal speaker-audience format.

A total of 238 people signed in at the open house meeting in Mountain Home and 130 people signed in at the open house meeting in Ingram. In some cases, only one spouse or family member signed in when more than one may have been present. All attendees were offered a questionnaire, a preliminary route segment map, and a frequently asked questions document (see Appendix B of the EA). LCRA TSC's ROW guide, The State of Texas Landowner's Bill of Rights, and the PUC's brochure entitled "Landowners and Transmission Line Cases at the PUC" were also available at the open houses. Some attendees handed in completed questionnaires at the meeting (totaling 123), while others took questionnaires with them, acquired questionnaires from neighbors, or accessed questionnaires from LCRA TSC's Mountain Home Project website. A total of 155 additional completed questionnaires were sent to LCRA TSC following the open house meetings. Thus, a total of 278 questionnaires were received by LCRA TSC at or following the public open house meetings. Additionally, LCRA TSC received public comments in the form of letters or emails.

Additional information concerning the public involvement program and summarizing the questionnaire results is located in Section 4.3.2, pages 4-3 through 4-7, of the EA. A representative copy of the questionnaires provided for the Proposed Project is included in Appendix B of the EA.

**APPLICATION OF LCRA TRANSMISSION SERVICES CORPORATION  
TO AMEND ITS CERTIFICATE OF CONVENIENCE AND NECESSITY  
FOR THE PROPOSED MOUNTAIN HOME 138-KV TRANSMISSION LINE PROJECT IN  
GILLESPIE, KERR, AND KIMBLE COUNTIES, TEXAS**

---

**19. Routing Maps:**

Base maps should be a full scale (one inch = not more than one mile) highway map of the county or counties involved, or other maps of comparable scale denoting sufficient cultural and natural features to permit location of all routes in the field. Provide a map (or maps) showing the study area, routing constraints, and all routes or line segments that were considered prior to the selection of the routes. Identify the routes and any existing facilities to be interconnected or coordinated with the project. Identify any taps, ties, meter points, or other facilities involving other utilities on the routing map. Show all existing transmission facilities located in the study area. Include the locations of radio transmitters and other electronic installations, airstrips, irrigated pasture or cropland, parks and recreational areas, historical and archeological sites (subject to the instructions in Question 27), and any environmentally sensitive areas (subject to the instructions in Question 29).

Provide aerial photographs of the study area displaying the date that the photographs were taken or maps that show (1) the location of each route with each route segment identified, (2) the locations of all major public roads including, as a minimum, all federal and state roadways, (3) the locations of all known habitable structures or groups of habitable structures (see Question 19 below) on properties directly affected by any route, and (4) the boundaries (approximate or estimated according to best available information if required) of all properties directly affected by any route.

For each route, cross-reference each habitable structure (or group of habitable structures) and directly affected property identified on the maps or photographs with a list of corresponding landowner names and addresses and indicate which route segment affects each structure/group or property.

**Base Maps**

Figures 4-25a and 4-25b of the EA (Appendix D), titled *Primary Alternative Routes with Environmental and Land Use Constraints*, produced at a scale of 1 inch = 0.25 mile, are provided in map pockets in the EA. These maps were produced using a U.S. Geological Survey (USGS) topographic base. They depict the study area for the project, locations of radio transmitters and other electronic installations, airports/airstrips, parks and recreational areas, historical sites, environmentally sensitive areas and other constraints. The maps also contain the alternative routes for the project. For their protection, locations of archeological sites are not shown on the maps.

Figures 5-1a and 5-1b of the EA (Appendix E), titled *Habitable Structures and Other Land Use Features in the Vicinity of the Primary Alternative Routes*, which consists of aerial photography produced at a scale of 1 inch = 0.25 mile, is provided in map pockets in the EA. The aerial photo-based maps include parcel boundaries identified from a

**APPLICATION OF LCRA TRANSMISSION SERVICES CORPORATION  
TO AMEND ITS CERTIFICATE OF CONVENIENCE AND NECESSITY  
FOR THE PROPOSED MOUNTAIN HOME 138-KV TRANSMISSION LINE PROJECT IN  
GILLESPIE, KERR, AND KIMBLE COUNTIES, TEXAS**

---

review of the tax appraisal district records and combined, as appropriate, to reflect instances where multiple parcels are owned by a single individual or group in the study area. The locations of all known habitable structures located within 300 feet of the centerline of primary alternative routes on properties directly affected by the project are also identified on Figure 5-1a and 5-1b. The habitable structures and other land use features map (Figure 5-1a and 5-1b, Appendix E of the EA) was produced using aerial imagery flown in March and November 2018.

Base maps include sufficient cultural and natural features to permit location of the alternative routes in the field, and they depict existing electric transmission lines (based on information available to POWER), and major public roads located within the study area, as applicable.

Maps showing the study area and all preliminary route segments in a format similar to EA Figures 4-25a, 4-25b, 5-1a, and 5-1b were presented at the public open house meeting. Figures 4-1 and 4-2 depict the preliminary route segments presented at the open houses.

**Directly Affected Property Maps**

Attachment 8 to this Application includes 15 maps (utilizing aerial photography) titled *Location of Directly Affected Parcels and Habitable Structures*, that identify directly affected properties, tract IDs, and the location of habitable structures (including labels) within at least 300 feet of the centerline of the transmission line alternatives and approximate parcel boundary lines (based on tax appraisal district records). These maps show the location of each proposed alternative route with each route segment identified, and the locations of all major public roads.

Attachment 10 to this Application is a list that cross-references each habitable structure, or group of habitable structures, and directly affected properties identified on the maps provided in Attachment 8 with a list of tract IDs and corresponding landowner names and addresses. Landowner names and addresses were obtained by review of information obtained from the Gillespie, Kerr and Kimble Appraisal Districts.

**APPLICATION OF LCRA TRANSMISSION SERVICES CORPORATION  
TO AMEND ITS CERTIFICATE OF CONVENIENCE AND NECESSITY  
FOR THE PROPOSED MOUNTAIN HOME 138-KV TRANSMISSION LINE PROJECT IN  
GILLESPIE, KERR, AND KIMBLE COUNTIES, TEXAS**

---

**20. Permits:**

**List any and all permits and/or approvals required by other governmental agencies for the construction of the proposed project. Indicate whether each permit has been obtained.**

Upon approval of the Application by the PUC, the following permits/approvals would be required and obtained prior to the commencement of construction:

- Where the approved route of the transmission line crosses a state-maintained road or highway, LCRA TSC will obtain a permit from the Texas Department of Transportation (TxDOT). If any portion of the transmission line will be accessed from a state-maintained road or highway, LCRA TSC will obtain a permit from TxDOT.
- Where the transmission line crosses a state-owned riverbed or navigable stream, LCRA TSC will obtain a Miscellaneous Easement (ME) from the General Land Office (GLO).
- Since more than one acre will be disturbed during construction of the project, a Storm Water Pollution Prevention Plan (SWPPP) will be necessary. Further, because more than five acres will be disturbed, a Notice of Intent (NOI) will be prepared by LCRA TSC for the Texas Commission on Environmental Quality (TCEQ). The controls specified in the SWPPP will be monitored in the field.
- Upon approval of the Application and prior to construction, a detailed Natural Resources Assessment (NRA) and Cultural Resources Assessment (CRA) will be performed on the approved route. Depending on the results of these assessments, permits or regulatory approvals may be required from the U.S. Army Corps of Engineers (USACE), U.S. Fish and Wildlife Service (USFWS), TCEQ, or Texas Historical Commission/State Historic Preservation Officer. Such permits or regulatory approvals will be obtained by LCRA TSC prior to construction.
- After alignments and structure locations/heights are designed and engineered, LCRA TSC will make a final determination of the need for Federal Aviation Administration (FAA) notification, based on structure locations and designs. In some areas, if necessary, LCRA TSC could use lower-than-typical structure heights and could add marking and/or lighting to certain structures to avoid or accommodate FAA requirements.
- LCRA TSC will report the status of the Proposed Project to the PUC on LCRA TSC's Monthly Construction Progress Report, beginning with the first report following the filing of a CCN application, and in each subsequent monthly progress report until construction is completed and actual project costs have been

**APPLICATION OF LCRA TRANSMISSION SERVICES CORPORATION  
TO AMEND ITS CERTIFICATE OF CONVENIENCE AND NECESSITY  
FOR THE PROPOSED MOUNTAIN HOME 138-KV TRANSMISSION LINE PROJECT IN  
GILLESPIE, KERR, AND KIMBLE COUNTIES, TEXAS**

---

reported. As required by the PUC, LCRA TSC will submit locational and attribute data for the new facilities along the approved route after it is constructed.

**21. Habitable structures:**

**For each route list all single-family and multi-family dwellings and related structures, mobile homes, apartment buildings, commercial structures, industrial structures, business structures, churches, hospitals, nursing homes, schools, or other structures normally inhabited by humans or intended to be inhabited by humans on a daily or regular basis within 300 feet of the centerline if the proposed project will be constructed for operation at 230kV or less, or within 500 feet of the centerline if the proposed project will be constructed for operation at greater than 230kV. Provide a general description of each habitable structure and its distance from the centerline of the route. In cities, towns or rural subdivisions, houses can be identified in groups. Provide the number of habitable structures in each group and list the distance from the centerline of the route to the closest and the farthest habitable structure in the group. Locate all listed habitable structures or groups of structures on the routing map.**

The locations of habitable structures within 300 feet of the centerline of each route segment are listed and described with the approximate distance from the route segment centerline in Appendix C, Tables 5-3 through 5-42 of the EA and are shown on Figure 5-1a and 5-1b in Appendix E of the EA. The total numbers of habitable structures for the 40 primary alternative routes are provided in the table below. Column two designates the number of habitable structures within 300 feet of the ROW centerline, while column three contains relevant information related to the number of habitable structures currently located within 300 feet of an existing transmission line ROW centerline. For a more detailed explanation of the relationship between these two metrics, see Section 5.2.3.1 of the EA.

<b>Primary Alternative Route</b>	<b>Total number of habitable structures within 300 feet of the centerline</b>	<b>Number of habitable structures currently located within 300 feet of the centerline of an existing transmission line</b>
<b>Hunt 1</b>	30	16
<b>Hunt 2</b>	36	16
<b>Hunt 3</b>	30	6
<b>Hunt 4</b>	26	2
<b>Hunt 5</b>	26	6

**APPLICATION OF LCRA TRANSMISSION SERVICES CORPORATION  
TO AMEND ITS CERTIFICATE OF CONVENIENCE AND NECESSITY  
FOR THE PROPOSED MOUNTAIN HOME 138-KV TRANSMISSION LINE PROJECT IN  
GILLESPIE, KERR, AND KIMBLE COUNTIES, TEXAS**

<b>Hunt 6</b>	28	6
<b>Hunt 7</b>	30	16
<b>Hunt 8</b>	31	16
<b>Hunt 9</b>	29	16
<b>Hunt 10</b>	50	16
<b>Hunt 11</b>	31	16
<b>Hunt 12</b>	31	16
<b>Hunt 13</b>	32	16
<b>Hunt 14</b>	31	16
<b>Hunt 15</b>	28	6
<b>Hunt 16</b>	29	6
<b>Hunt 17</b>	31	6
<b>Hunt 18</b>	23	16
<b>Hunt 19</b>	30	16
<b>Hunt 20</b>	25	16
<b>Hunt 21</b>	30	16
<b>Hunt 22</b>	40	16
<b>Hunt 23</b>	40	6
<b>Hunt 24</b>	30	7
<b>Hunt 25</b>	32	6
<b>Hunt 26</b>	29	2
<b>Hunt 27</b>	48	6
<b>Hunt 28</b>	27	7
<b>Hunt 29</b>	35	6
<b>Hunt 30</b>	37	6
<b>Ingram 1</b>	60	4
<b>Ingram 2</b>	76	3
<b>Ingram 3</b>	72	3
<b>Ingram 4</b>	35	3
<b>Ingram 5</b>	39	3
<b>Ingram 6</b>	32	3
<b>Ingram 7</b>	28	4

**APPLICATION OF LCRA TRANSMISSION SERVICES CORPORATION  
TO AMEND ITS CERTIFICATE OF CONVENIENCE AND NECESSITY  
FOR THE PROPOSED MOUNTAIN HOME 138-KV TRANSMISSION LINE PROJECT IN  
GILLESPIE, KERR, AND KIMBLE COUNTIES, TEXAS**

---

<b>Ingram 8</b>	45	31
<b>Ingram 9</b>	44	31
<b>Ingram 10</b>	46	31

**22. Electronic Installations:**

**For each route, list all commercial AM radio transmitters located within 10,000 feet of the center line of the route, and all FM radio transmitters, microwave relay stations, or other similar electronic installations located within 2,000 of the center line of the route. Provide a general description of each installation and its distance from the center line of the route. Locate all listed installations on a routing map.**

There are no known commercial AM radio transmitters located within 10,000 feet of any of the primary alternative routes. There are nine known communication towers (FM radio transmitters, microwave towers, or other electronic communications towers) that are located within 2,000 feet of any of the primary alternative routes. A listing, description, and approximate distance from the centerline of each of the primary alternative routes are presented in Table 5-45 and in Appendix C, Tables 5-3 through 5-42 of the EA, and the locations of these electronic installations are shown on Figures 4-25a, 4-25b (Appendix D), 5-1a and 5-1b (Appendix E) of the EA.

For additional information on electronic installations, see Section 2.8.5 and Section 5.2.6 of the EA. None of the routes filed in this Application are anticipated to have any impact on the existing communication towers.



**APPLICATION OF LCRA TRANSMISSION SERVICES CORPORATION  
TO AMEND ITS CERTIFICATE OF CONVENIENCE AND NECESSITY  
FOR THE PROPOSED MOUNTAIN HOME 138-KV TRANSMISSION LINE PROJECT IN  
GILLESPIE, KERR, AND KIMBLE COUNTIES, TEXAS**

---

**23. Airstrips:**

**For each route, list all known private airstrips within 10,000 feet of the center line of the project. List all airports registered with the Federal Aviation Administration (FAA) with at least one runway more than 3,200 feet in length that are located within 20,000 feet of the center line of any route. For each such airport, indicate whether any transmission structures will exceed a 100:1 horizontal slope (one foot in height for each 100 feet in distance) from the closest point of the closest runway. List all listed airports registered with the FAA having no runway more than 3,200 feet in length that are located within 10,000 feet of the center line of any route. For each such airport, indicate whether any transmission structures will exceed a 50:1 horizontal slope from the closest point of the closest runway. List all heliports located within 5,000 feet of the center line of any route. For each such heliport, indicate whether any transmission structures will exceed a 25:1 horizontal slope from the closest point of the closest landing and takeoff area of the heliport. Provide a general description of each listed private airstrip, registered airport, and heliport; and state the distance of each from the center line of each route. Locate and identify all listed airstrips, airports, and heliports on a routing map.**

POWER's review of federal and state aviation/airport maps and directories, aerial photo interpretation and reconnaissance surveys, as well as information received from the TxDOT Division of Aviation, identified no FAA registered heliports located within 5,000 feet of the centerline of any of the primary alternative routes, no FAA registered public or military airports with runways longer than 3,200 feet identified within 20,000 feet of the routes, and no FAA registered public or military airports with runways shorter than 3,200 feet identified within 10,000 feet of the routes. Three FAA-listed private airstrips and three non FAA-listed private airstrips (one with a pending listing) were identified within 10,000 feet of the centerline of one or more primary alternative routes. Three private non FAA-listed heliports were identified within 5,000 feet of the centerline of one or more primary alternative routes.

Each airport/airstrip/heliport is listed and described with the approximate distance from the centerline of each of the primary alternative routes in Table 5-43 and Appendix C, Tables 5-3 through 5-42 of the EA. These facilities are shown on Figures 4-25a, 4-25b (Appendix D), 5-1a and 5-1b (Appendix E) of the EA.

For additional information on airports/airstrips, see Section 2.8.4 and Section 5.2.4.2 of the EA. No significant impacts to these airports/airstrips/heliports are anticipated from construction of the Proposed Project. Following approval of a route by the PUC, LCRA TSC will make a final determination of the need for FAA notification, based on specific route location and structure design. The result of this notification, and any subsequent coordination with FAA, could include changes in the line design and/or potential requirements to mark and/or light the structures.

**APPLICATION OF LCRA TRANSMISSION SERVICES CORPORATION  
TO AMEND ITS CERTIFICATE OF CONVENIENCE AND NECESSITY  
FOR THE PROPOSED MOUNTAIN HOME 138-KV TRANSMISSION LINE PROJECT IN  
GILLESPIE, KERR, AND KIMBLE COUNTIES, TEXAS**

---

**24. Irrigation Systems:**

**For each route identify any pasture or cropland irrigated by traveling irrigation systems (rolling or pivot type) that will be traversed by the route. Provide a description of the irrigated land and state how it will be affected by each route (number and type of structures etc.). Locate any such irrigated pasture or cropland on a routing map.**

Based on POWER's review of aerial photography and field reconnaissance, no primary alternative route of the Proposed Project crosses any known cropland or pastureland irrigated by traveling irrigation systems, either rolling or pivot type.

**25. Notice:**

**Notice is to be provided in accordance with 16 TAC 22.52.**

**A. Provide a copy of the written direct notice to owners of directly affected land. Attach a list of the names and addresses of the owners of directly affected land receiving notice.**

A copy of the written notice, with attachments, mailed to owners of directly-affected land is included as Attachment 9 to the Application. A list of the names and addresses of those owners of directly affected land to whom notice was mailed by first-class mail is included as Attachment 10 to this Application. Landowners of record and their mailing addresses were determined by review of information obtained from the Gillespie, Kerr, and Kimble Appraisal District.

**B. Provide a copy of the written notice to utilities that are located within five miles of the routes.**

A copy of the written notice sent to utilities located within five miles of the Proposed Project is included as Attachment 11 to this Application. LCRA TSC additionally sent notice of the Application to owners/operators of existing and proposed metallic pipelines six inches in diameter and greater carrying hydrocarbons that are parallel and adjacent to or crossed by primary route segments included in the Application. The names and addresses of utilities and pipeline owners/operators to whom written notice was sent are included in Attachment 12, pages 1 and 5 to this Application.

**APPLICATION OF LCRA TRANSMISSION SERVICES CORPORATION  
TO AMEND ITS CERTIFICATE OF CONVENIENCE AND NECESSITY  
FOR THE PROPOSED MOUNTAIN HOME 138-KV TRANSMISSION LINE PROJECT IN  
GILLESPIE, KERR, AND KIMBLE COUNTIES, TEXAS**

---

- C. Provide a copy of the written notice to county and municipal authorities, and the Department of Defense Siting Clearinghouse. Notice to the DoD Siting Clearinghouse should be provided at the email address found at <http://www.acq.osd.mil/dodsc/>.**

A copy of the written notice sent to county and municipal authorities and the Department of Defense Siting Clearinghouse is included as Attachment 11 to this Application. The names and addresses of county and municipal authorities and the Department of Defense Siting Clearinghouse to whom the written notices were sent are included in Attachment 12, pages 2 and 4 to this Application. The same notice was sent to utilities, counties, municipal authorities, and the Department of Defense Siting Clearinghouse. LCRA TSC additionally sent notification of the application to the Texas Office of Public Utility Counsel (Attachment 12, page 1), independent school districts (Attachment 12, page 3), state and federal elected officials (Attachment 12, page 4), and TxDOT Area Engineers (Attachment 12, page 1).

- D. Provide a copy of the notice that is to be published in newspapers of general circulation in the counties in which the facilities are to be constructed. Attach a list of the newspapers that will publish the notice for this application. After the notice is published, provide the publisher's affidavits and tear sheets.**

A copy of the public notice that will be published in the *Fredericksburg Standard-Radio Post*, *Kerrville Daily Times*, *West Kerr Current*, and *Junction Eagle* (newspapers of general circulation in Gillespie County – *Fredericksburg Standard-Radio Post*, Kerr County – *Kerrville Daily Times* & *West Kerr Current* and Kimble County – *Junction Eagle* where the transmission facilities are to be constructed) once for one week after the Application is filed with the PUC is included as Attachment 13 to the Application. Publisher's affidavits and tear sheets will be filed with the PUC showing proof of notice as soon as available after filing of the Application.

**For a CREZ application, in addition to the requirements of 16 TAC § 22.52 the applicant shall, not less than twenty-one (21) days before the filing of the application, submit to the Commission staff a “generic” copy of each type of alternative published and written notice for review. Staff's comments, if any, regarding the alternative notices will be provided to the applicant not later than seven days after receipt by Staff of the alternative notices, Applicant may take into consideration any comments made by Commission staff before the notices are published or sent by mail.**

Not applicable.

**APPLICATION OF LCRA TRANSMISSION SERVICES CORPORATION  
TO AMEND ITS CERTIFICATE OF CONVENIENCE AND NECESSITY  
FOR THE PROPOSED MOUNTAIN HOME 138-KV TRANSMISSION LINE PROJECT IN  
GILLESPIE, KERR, AND KIMBLE COUNTIES, TEXAS**

---

**26. Parks and Recreation Areas:**

**For each route, list all parks and recreational areas owned by a governmental body or an organized group, club, or church and located within 1,000 feet of the center line of the route. Provide a general description of each area and its distance from the center line. Identify the owner of the park or recreational area (public agency, church, club, etc.). List the sources used to identify the parks and recreational areas. Locate the listed sites on a routing map.**

POWER reviewed USGS topographic maps, TxDOT county highway maps, recent aerial photography, and field reconnaissance to identify parks and recreation areas within the study area. Based on this review, POWER identified two parks or recreation areas (TxDOT rest areas along IH 10) located within 1,000 feet of the centerline of one or more of the primary alternative routes.

For more information on parks and recreational areas see Section 2.8.6 and Section 5.2.5 of the EA. No significant impacts to the use of the parks and recreation facilities located within the study area are anticipated from any of the primary alternative routes.

**27. Historical and Archeological Sites:**

**For each route, list all historical and archeological sites known to be within 1,000 feet of the center line of the route. Include a description of each site and its distance from the center line. List the sources (national, state or local commission or societies) used to identify the sites. Locate all historical sites on a routing map. For the protection of the sites, archeological sites need not be shown on maps.**

POWER conducted a literature review and records search at the Texas Historical Commission and The Texas Archeological Research Laboratory at the University of Texas at Austin to identify known historical and archaeological sites located within 1,000 feet of the centerline of each of the primary alternative routes. For more information regarding site descriptions and the evaluation of the historical and archaeological sites located within the study area, see Section 2.11 and Section 5.3 of the EA.

Based on POWER's review, 30 recorded archeological sites are located within 1,000 feet of the centerline of one or more of the primary alternative routes. Eight of the identified sites are crossed by primary alternative route ROWs. All of the sites are recorded as prehistoric sites. These sites are listed and described with the approximate distance from the centerline for each of the primary alternative routes in Table 5-46 and Appendix C, Tables 5-3 through 5-42 of the EA. For the protection of these sites, they are not shown on the routing maps.

**APPLICATION OF LCRA TRANSMISSION SERVICES CORPORATION  
TO AMEND ITS CERTIFICATE OF CONVENIENCE AND NECESSITY  
FOR THE PROPOSED MOUNTAIN HOME 138-KV TRANSMISSION LINE PROJECT IN  
GILLESPIE, KERR, AND KIMBLE COUNTIES, TEXAS**

---

**28. Coastal Management Program:**

**For each route, indicate whether the route is located, either in whole or in part, within the coastal management program boundary as defined in 31 TAC §503.1. If any route is, either in whole or in part, within the coastal management program boundary, indicate whether any part of the route is seaward of the Coastal Facilities Designation Line as defined in 31 TAC §19.2(a)(21). Using the designations in 31 TAC §501.3(b), identify the type(s) of Coastal Natural Resource Area(s) impacted by any part of the route and/or facilities.**

No part of any primary alternative route is located within the Coastal Management Program boundary, as defined in 31 TAC § 503.1.

**29. Environmental Impact:**

**Provide copies of any and all environmental impact studies and/or assessments of the project. If no formal study was conducted for this project, explain how the routing and construction of this project will impact the environment. List the sources used to identify the existence or absence of sensitive environmental areas. Locate any environmentally sensitive areas on a routing map. In some instances, the location of the environmentally sensitive areas or the location of protected or endangered species should not be included on maps to ensure preservation of the areas or species. Within seven days after filing the application for the project, provide a copy of each environmental impact study and/or assessment to the Texas Parks and Wildlife Department (TPWD) for its review at the address below. Include with this application a copy of the letter of transmittal with which the studies/assessments were or will be sent to the TPWD.**

**Wildlife Habitat Assessment Program  
Wildlife Division  
Texas Parks and Wildlife Department  
4200 Smith School Road  
Austin, Texas 78744**

**The applicant shall file an affidavit confirming that the letter of transmittal and studies/assessments were sent to TPWD.**

The EA describes the natural resources, cultural resources, land uses, and other sensitive areas that may occur within the study area. The EA also describes how the Proposed Project may impact such resources. Specifically, the EA includes data obtained from TPWD, including the Texas Natural Diversity Database (TXNDD) and a list of Ecologically Significant Stream Segments (ESSS) in the study area.

LCRA TSC will provide a copy of the EA to TPWD within seven days after the Application is filed. A copy of the letter of transmittal of the EA to TPWD is provided as

**APPLICATION OF LCRA TRANSMISSION SERVICES CORPORATION  
TO AMEND ITS CERTIFICATE OF CONVENIENCE AND NECESSITY  
FOR THE PROPOSED MOUNTAIN HOME 138-KV TRANSMISSION LINE PROJECT IN  
GILLESPIE, KERR, AND KIMBLE COUNTIES, TEXAS**

---

Attachment 14 to this Application. An affidavit confirming that the letter of transmittal and a copy of the EA were sent to TPWD will be filed with the PUC.

**30. Affidavit**

*Attach a sworn affidavit from a qualified individual authorized by the applicant to verify and affirm that, to the best of their knowledge, all information provided, statements made, and matters set forth in this application and attachments are true and correct.*

A sworn affidavit is attached below.